

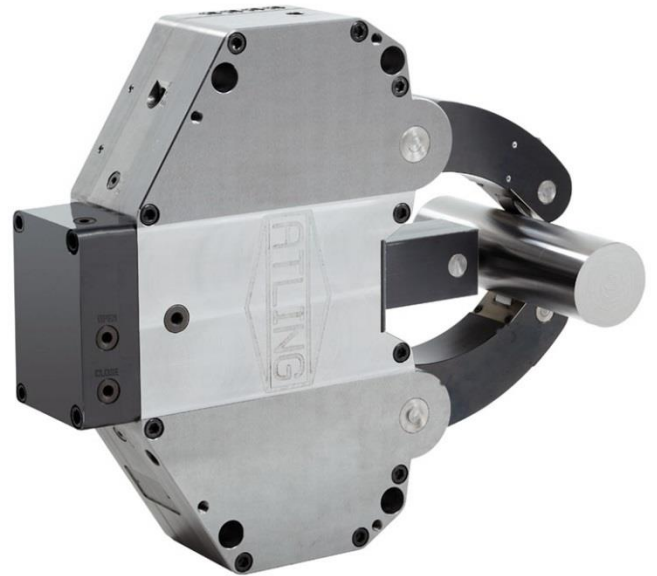

Operator's manual

www.atling.com

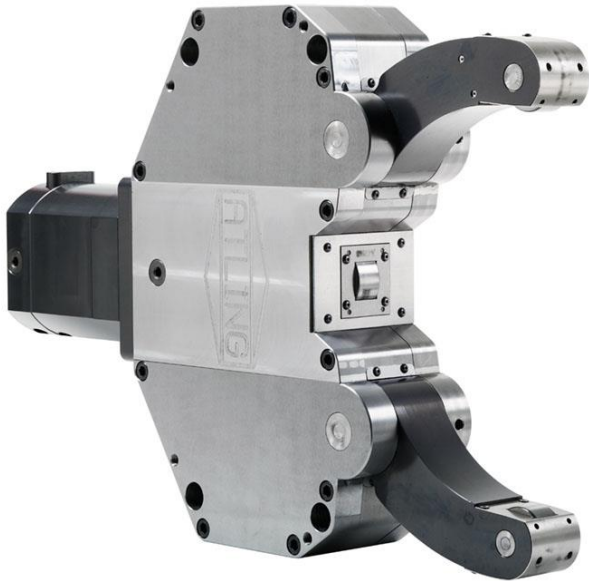

Self-centring Steady Rests –
hydraulic and pneumatic designs
AXE, ASE, ANE, AXI, ASI series



Thoroughly read and make sure you understand the contents of this manual before using the Steady Rest



ATLING – THE STEADY REST COMPANY
www.atling.com

Declaration of Conformity

Atlings Maskinfabrik AB förklarar härmed att nedanstående utrustning uppfyller alla relevanta bestämmelser i **2006/42/EG** EG-direktiv och de nationella lagar och förordningar där dessa direktiv är införlivade.

Atlings Maskinfabrik AB hereby certifies that the device described below in all respects complies to the requirements of the **2006/42/EC** EC-directive and the national laws where this directive is incorporated.

Självcentrerade stöddockor L../AX.. i pneumatik- eller hydraulikutförande avsedd att användas inmonterad i annan maskin.
Stöddockan får inte tas i bruk förrän den maskin eller anläggning som den skall ingå i överensstämmer med kraven i EG´s maskindirektiv

Self-centering Steady Rests L../AX.. of pneumatic or hydraulic design, intended to be built into other machinery.
The Steady Rest must not be put into service until the specific machinery or construction which it is part of conforms to the specifications in EC´s directive.

Component:

Steady Rest

Application:

Installation in machine

Type:

AX3E-BAOC (ø12-125)

Serial No:

3010737

Signature of responsible person

Om utrustningen modifierats utan föregående godkännande från undertecknad är denna deklaration ogiltig.

If the devices are modified without written approval from the signee, this declaration is void.

Tillverkare / Manufacturer

Atlings Maskinfabrik AB
Box 21
816 25 Ockelbo



Steady Rest, models AXE, ASE, ANE, AXI, ASI

Dear customer,

Thank you for choosing a product from Atlings Maskinfabrik AB. Our products are characterised by high quality and precision. Through active cooperation with our distributors, we aim for the highest possible service level to fulfil your expectations.

To be able to use the Atling Steady Rest in the best possible way, and to maintain it properly, we recommend that you read and make sure you understand the contents of this operator's manual. This is to ensure you can benefit from all the useful features that the Steady Rest offers.

There are also exploded views of the product to help you understand how it is designed. You can use these as maintenance and service support.

If you have any questions, don't hesitate to contact Atling or your nearest distributor. We welcome any feedback that helps us improve the Steady Rest further.

Atlings Maskinfabrik AB

Atlings Maskinfabrik AB
Hamrångevägen 23
816 31 Ockelbo
Sweden

Tel + 46 (0)297 55700

steadyrest@atling.se
www.steadyrest.se



Declaration of Conformity	2
1. Safety instructions.....	6
2. Main components and designations.....	7
2.1. External cylinder model.....	7
2.2. Internal cylinder model.....	8
3. General.....	9
3.1. Cylinder	9
3.2. Wipers	9
3.3. Pressure booster	9
3.4. Position indicator (External cylinder).....	9
3.5. Coolant.....	9
3.6. Accessories	10
4. Conditions for use	11
4.1. Clamping force and working pressure	11
4.2. The purity of the hydraulic system (Internal cylinder)	11
4.3. Idling Steady Rest	11
4.4. Air barrier or drainage	11
4.5. Lubricating system	11
4.6. Recommended lubricants	12
4.7. Suggested lubrication charts.....	12
5. Installation	13
5.1. Delivery check.....	13
5.2. Machine check	13
5.3. Necessary equipment	13
5.4. Checking the installation and adjustments.....	14
5.5. Checking the Steady Rest bracket.....	14
5.6. Rinsing the hydraulic system	14
5.7. Lifting the Steady Rest	15
5.8. Mounting the Steady Rest on a bracket or an adapter plate	15
5.9. Mounting adjustment devices.....	16
5.10. Connecting the hydraulics for opening and closing	16
5.11. Hydraulic connection.....	17
5.12. Coolant flush through levers	18
5.13. Connecting coolant/cooling air	18
5.14. Lubrication connection (Automatic oil lubrication).....	18
5.15. Connecting pneumatic over pressure	19
5.16. Installing inductive position indicators (External cylinder).....	20
6. Centring the Steady Rest	21
6.1. Checking the straightness.....	21
6.2. Mounting the gauges.....	21
6.3. The first clamping with the Steady Rest.....	22
6.4. Removing the centre	22
6.5. Adjusting the Steady Rest.....	22
6.6. Conclusion.....	23
6.7. Installing or replacing an extra opening lever	23
6.8. Data table for installation.....	23
6.9. Pressure and clamping forces.....	24
7. Maintenance	26
7.1. Manual lubrication	26
7.2. Central lubrication	26
7.3. Other maintenance work	26
7.4. Replacing the rollers and middle piece wiper	27
7.5. Replacing the rollers and lever wiper	28
7.6. Removing cylinder (external cylinder).....	29



8. Spare parts	30
8.1. Exploded view – AXE, ASE.....	30
8.2. Exploded view – ANE.....	31
8.3. Exploded view – Cylinder AXE, ASE, ANE	32
8.4. Exploded view – AXI, ASI	33
8.5. Exploded view – Cylinder AXI, ASI	34
8.6. Spare kit part number.....	35
9. Notes	39

1. Safety instructions



Incorrect installation and/or use of this product may result in serious or even fatal injuries. All staff that use the Steady Rest in any way must have read and understood the contents of this manual first. If anything is uncertain, contact Atling or your distributor.

- Atling's Steady Rest is equipped with a safety valve that prevents the Steady Rest from suddenly losing its working pressure, for instance if a hose should burst. A loss of working pressure may result in that the steady rest loses its grip around the workpiece, causing personal injury and equipment damage. The Steady Rest should however not be used unless there is a working pressure, and the safety valve does not guarantee a maintained working pressure for an extended amount of time.
- You should check at least once a year that the safety valve is working properly.
- Do not exceed the maximum pressure of the Steady Rest; this can be found on the data plate Which is attached to the Steady Rest.
- Check the screw joints between the Steady Rest and its bracket at least once per week; vibrations can lead to the fastening screws coming undone.
- Note that the levers are a crush hazard.
- When operating the Steady Rest, make sure hands and other body parts are not near the Steady Rest or the workpiece.
- When using an idling Steady Rest, the workpiece must not have sharp edges or detachments. In these cases, for models with an external cylinder, the safety valve should also be disconnected and replaced by a blind plug, and for models with an internal cylinder, the standard pressure booster should be replaced by another pressure booster without a built-in safety valve.
- The workpiece where the Steady Rest clamps must be centred in relation to the centre line between the chuck and the mandrel.
- Adjust the pressure according to the weight and shape of the workpiece, as well as for the cutting forces of the machining.
- Always be careful when working with pressurised systems.
- To avoid damage to the Steady Rest, no unprocessed surfaces of the workpiece should be clamped.
- The result of the machining will never be better than the accuracy of the surface that the Steady Rest is clamped to.
- If the work pressure is too high, the rollers will be rolled into the workpiece. The life-span of the rollers will be considerably shortened if the work pressure is too high

2. Main components and designations

2.1. External cylinder model

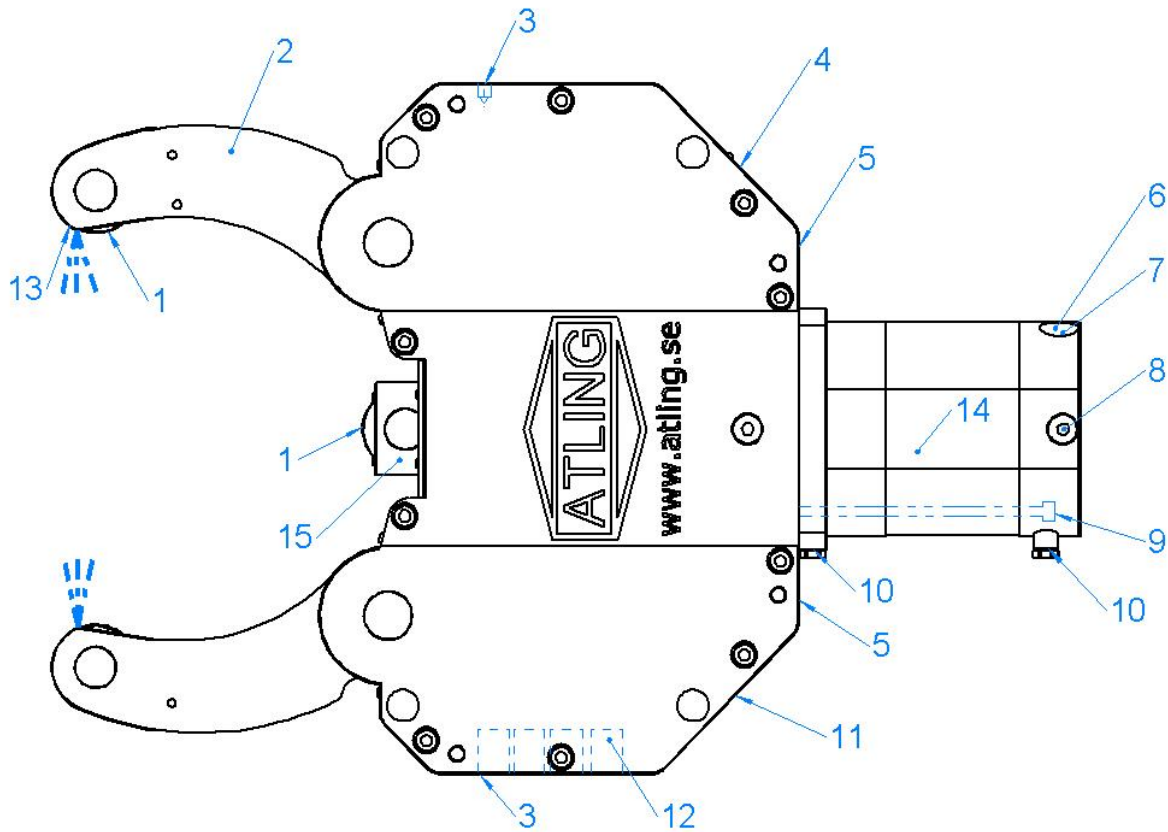

Figure 1 Steady rest with external cylinder - AXE, ASE, ANE series

- | | |
|------------------------------------|--|
| 1. Roller | 9. Position indicator |
| 2. Lever | 10. Connections for inductive sensors |
| 3. Thread for eye bolt | 11. Connection for central lubrication |
| 4. Coolant connection | 12. Metering valves |
| 5. Air barrier or drainage | 13. Coolant outlet |
| 6. Connection for cylinder opening | 14. Cylinder |
| 7. Connection for cylinder closing | 15. Middle piece |
| 8. Safety valve | |

2.2. Internal cylinder model

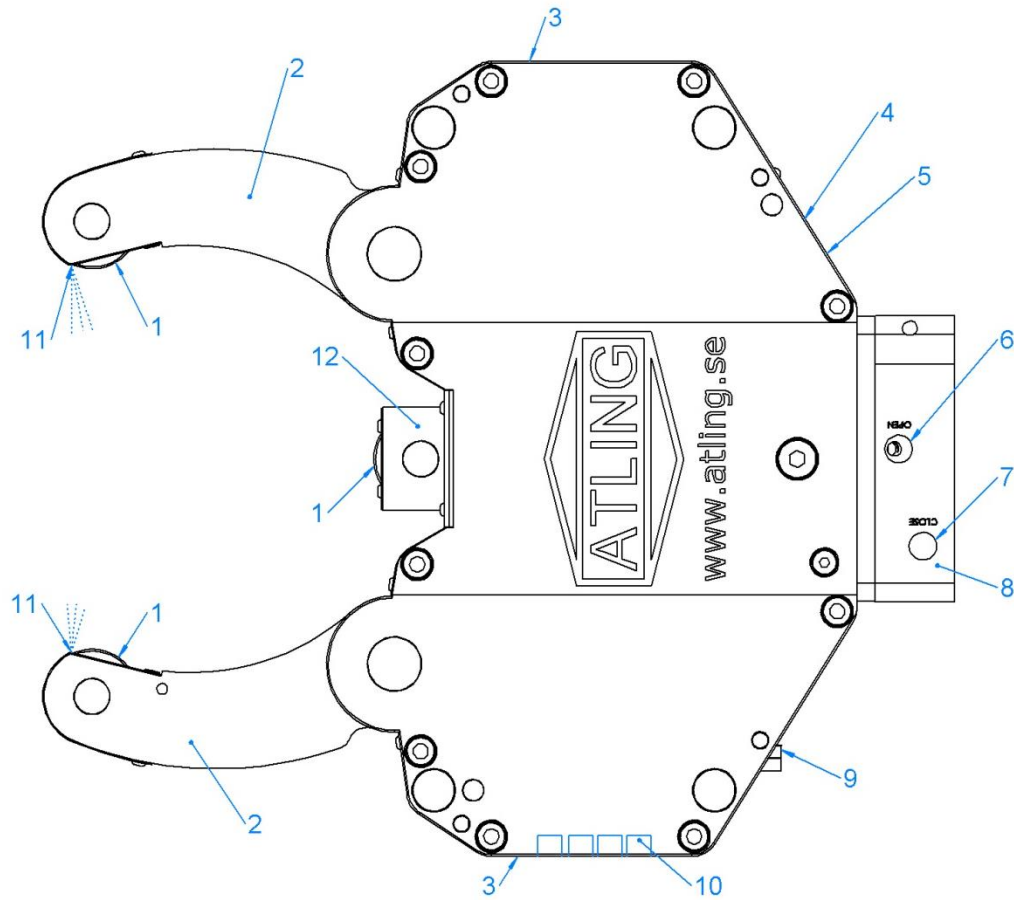

Figure 2. Steady Rest with built-in cylinder and pressure booster – AXI, ASI series

- | | |
|------------------------------------|--|
| 1. Roller | 7. Connection for cylinder closing |
| 2. Lever | 8. Pressure booster with built-in safety valve |
| 3. Thread for eye bolt | 9. Connection for central lubrication |
| 4. Coolant connection | 10. Metering valves |
| 5. Air barrier or Drainage | 11. Coolant outlet |
| 6. Connection for cylinder opening | 12. Middle Piece |



3. General

Atling's Steady Rests are usually used in lathes and grinding machines, manually or automatically operated with flat or slanted beds. The Steady Rest can also be used for customized applications, such as handling long hexagon bars and as a gripper in robots.

3.1. Cylinder

Atling's Steady Rests can be hydraulically or pneumatically controlled. The force is directly transferred to the middle piece, which acts on the levers and together stabilising the workpiece. By adjusting the pressure that goes into the Steady Rest, the clamping force can be set to a suitable level. Each Steady Rest has a maximum allowed pressure. This can be found on the data plate on the Steady Rest.

3.2. Wipers

Atling's wipers make sure dirt is removed from the rollers. The state of the wipers should be checked regularly and they should be changed when needed. The levers and the middle piece are sealed to the housing in order to prevent dirt and chips from entering the housing.

3.3. Pressure booster

The AXI/ASI Steady Rest features a pressure booster which increases the input pressure four times, thereby compensating for a smaller cylinder area compared to the AXE/ASE models. For that reason, the same working pressure can be used as for the corresponding size in the AXE/ASE models. If the pressure should decrease, the pressure booster will automatically build up the pressure. A ticking sound will be heard from the pressure booster as the pressure builds up; this sound should, however, stop as the goal pressure has been reached which should happen a few seconds after the Steady Rest has clamped the workpiece. The hydraulic filtering should be 10 µm nominal; maximum 19/16 according to ISO 4406. The pressure booster, which is used for internal cylinders, has a built-in safety valve.

3.4. Position indicator (External cylinder)

If adjustable position indication is needed, there are two holders for inductive sensors on the cylinder housing, see section 5.16 for instructions on how to install or adjust position indicators. Inductive sensors are sold separately. If just one position is to be checked, just one sensor needs to be installed.

3.5. Coolant

The housing of the Steady Rest can be connected to the coolant system. The coolant is then led into the levers and forms a curtain that prevents chips from getting between the rollers and the workpiece.

3.6. Accessories

There are some accessories which are not included as standard. Some examples are:

Workpiece wipers

There are two types of wipers for the workpiece that remove chips and dirt. Both wipers are attached to the levers with two screws; the position of the manual wiper must then be adjusted, depending on the diameter of the workpiece.

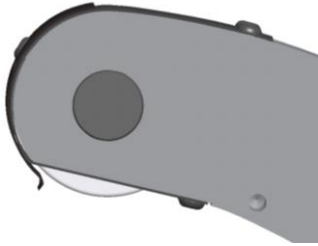

Figure 4. Wiper with manual adjustment

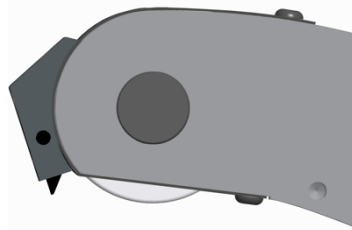

Figure 3. Self adjusting wiper

Steady Rest bracket

The bracket must be ordered separately and fits the machine's fastener and the Steady Rest. In order to use the Steady Rest in the best possible way, the bracket must have a stable design.

The design of the bracket is determined mainly by the following:

- The design of the Steady Rest
- The shape of the machine bed
- The position of the centre line mandrel in relation to the machine bed
- The space available to mount the Steady Rest

Accuracy must be used when designing and mounting the bracket, so that it is perpendicular to the machine bed.

Some examples of brackets where the Steady Rest is mounted:

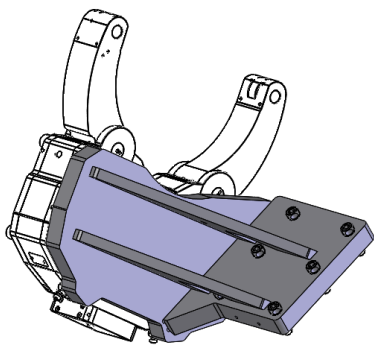

Slanted bed bracket, to mount at steady rest base.

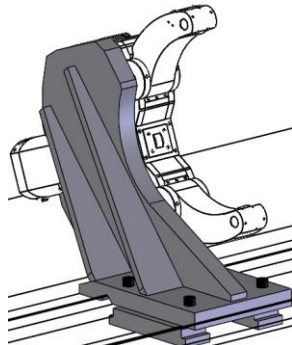

Flat bed bracket, mounted at the machine bed.

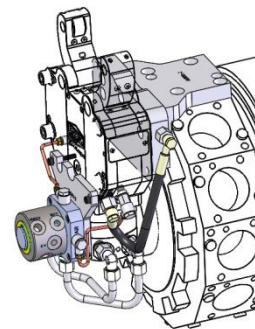

Turret bracket including swivel.

4. Conditions for use

The self-centring Steady Rest requires a lathed or a grinded workpiece that is centred to the machine centre. Three rollers (see Figure 1) spaced at approximately 120 degrees, centralizes the workpiece by cam controlled levers. This provides accurate centring of the workpiece throughout the clamping range. To avoid damage to the Steady Rest and the rollers, only machined surfaces should be clamped.

4.1. Clamping force and working pressure

If the maximum clamping forces are used, the life span of the rollers is considerably shortened. Very high clamping forces usually do not mean better machining results, but may result that the rollers leave marks on the workpiece. The working pressure of the Steady Rest depends on the need for clamping. The parameters governing this are: cutting force, speed and the quality of the workpiece.

Note. The result of the machining will never be better than the accuracy of the surface that the Steady Rest is clamped to.

4.2. The purity of the hydraulic system (Internal cylinder)

In order to fulfil the recommendations for the pressure booster, the filtering of the hydraulic system is 10 µm nominal; 19/16 according to ISO 4406. In conditions with larger and more dense particles, the internal components of the pressure booster risk getting damaged.

- ✓ **It's very important to have clean hydraulic oil, especially in the AXI/ASI-models where a pressure booster is installed!**



- ✓ **Filtration of hydraulic oil is necessary, down to particle size of 10 µm.**

- ✓ **Do not use thread tape or thread sealant as for example Loctite or similar product for the hydraulic system! Use hydraulic couplings and seals instead!**



Don't use thread tape



Oil filter unit



4.3. Idling Steady Rest

When a Steady Rest is going to travel along the work piece it is necessary to use cambered rollers, which are more spherical than standard. In such cases, the selection of rollers should be discussed with the distributor.

4.4. Air barrier or drainage

To prevent dirt and chips from entering the housing of the Steady Rest, compressed air with an excess pressure of 0.5 bar should be connected to the housing. Connect it via the air/drainage connection (see Figure 1, position 5). This is an important but easy feature to extend the life span of the Steady Rest and its components.

4.5. Lubricating system

Atling's Steady Rests can be automatically lubricated with oil, manually with grease or automatically with grease. If the Steady Rest has been ordered intended for oil lubrication it will be delivered with a G1/8" connection and metering valves. If the Steady Rest has been ordered intended for manual grease lubrication, it will be delivered with a G1/8" threaded grease nipple. If the Steady Rest has been ordered intended for automatic grease lubrication, it will be delivered with 4 G1/8" threaded grease nipples. Changes to the lubrication type can not be made without modifying the Steady Rest. Contact Atling or your distributor for instructions.

The following applies to central oil lubrication:

- Four (three in AX1E) metering valves are integrated in the Steady Rest housing and connected to the machine's main lubrication system for oil or a separate oil lubrication unit.
- The volume of the metering valves varies between 0.03 cm³–0.06 cm³ for each moment of lubrication.
- The working pressure of the metering valves must be between 12–45 bar.
- Discharge pressure maximum 3 bar.
- The Steady Rest lubrication impulse intervals should be 3–5 minutes
- If the equipment has not been used for an extended period of time, repeated lubrication impulses should be given before starting the machining, to make sure the lubrication channels are filled.

The following applies to automatic greasing:

With automatic greasing systems, the Steady Rest contains no integrated metering valves, but these are usually part of the lubricating system of the machine, for connecting 4 hoses (3 for AX1E/AN1E) to the Steady Rest.

4.6. Recommended lubricants

The table below indicates the greases and oils recommended by Atling.

Load	Grease
Normal loads	DIN 51825-1 to 3
High loads	KP grease according to DIN 51502
Lubricating oil	
All loads	DIN 51502 with EP additive

4.7. Suggested lubrication charts

The figures below show a number of suggested lubrication charts.

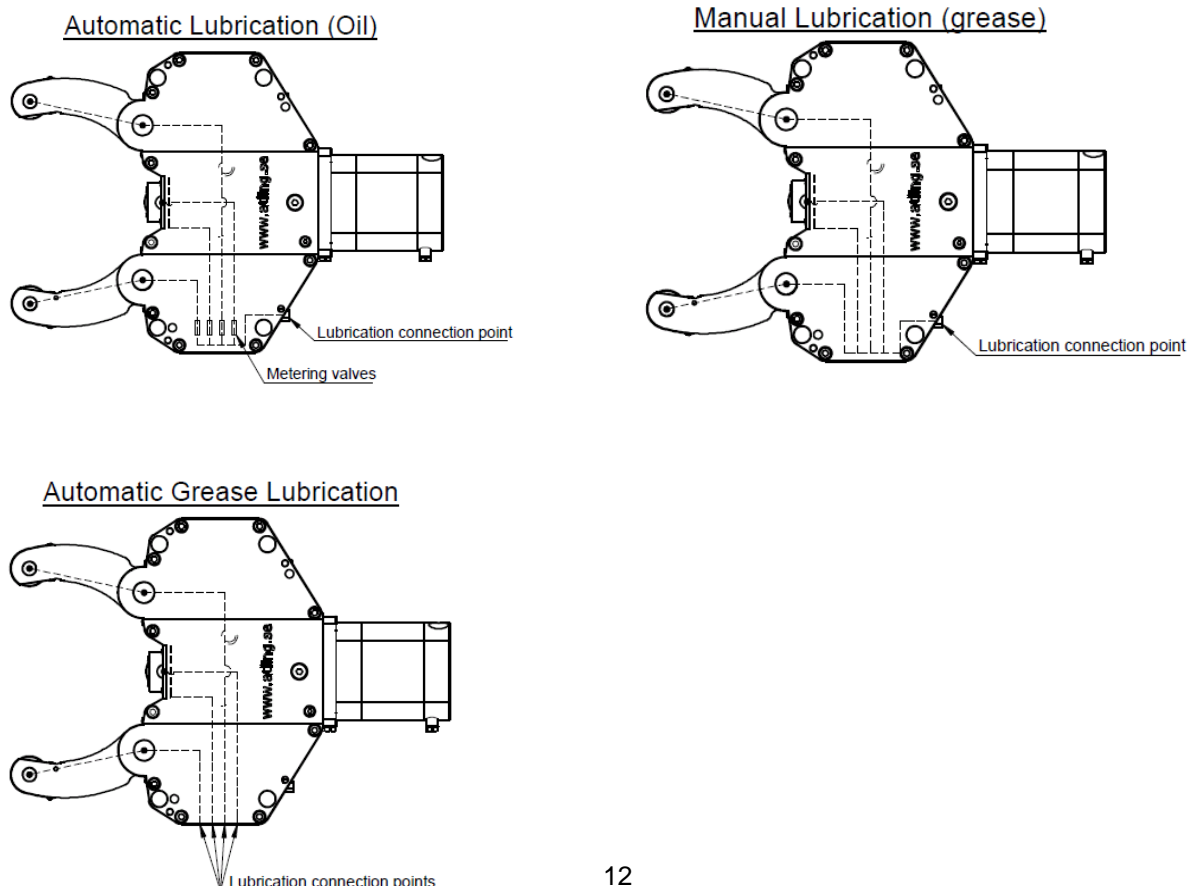

5. Installation



The installation of the Steady Rest must be made with the utmost care. Incorrect installation will cause malfunction or damage to the Steady Rest. It is important to follow the installation instructions carefully. All staff that use the Steady Rest in any way must have read and understood the contents of this manual first. If anything is uncertain, contact Atling or your nearest distributor.

Before installing:

- Make sure the Steady Rest can be installed in the machine without exposing the installation staff, or other staff who work nearby to any risk.
- Cut and lock all incoming power; hydraulic, compressed air etc. to the machine, with a personal lock.

5.1. Delivery check

Check all parts that have been delivered to see that they are OK and according to your order.

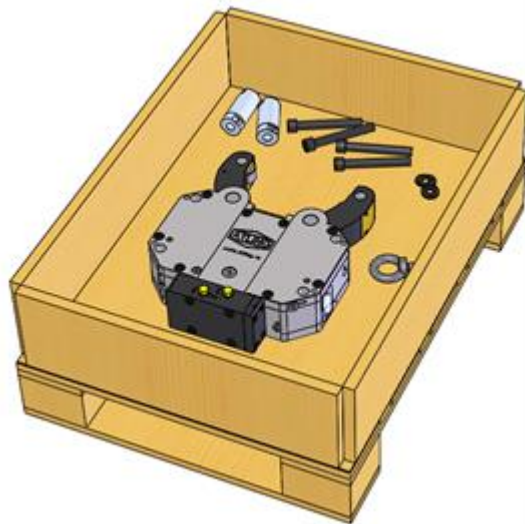

5.2. Machine check

Before starting the installation of the machine, check points 5.3–5.6 below!

5.3. Necessary equipment

Check that the machine has the equipment required for the delivered Steady Rest and that the machine can be used to run the Steady Rest, like a hydraulic unit, a hydraulic directional valve, coolant, lubricant, compressed air for the excess pressure barrier, position indicator connections etc.

5.4. Checking the installation and adjustments

Check that the installation of the machine is ready and that all measurements that may affect the Steady Rest are correct, like the chuck, the machine bed, the Steady Rest base and the tailstock.

5.5. Checking the Steady Rest bracket

Check and adjust the Steady Rest bracket so that the angle is 90° to the machine bed and the chuck centre of the machine.

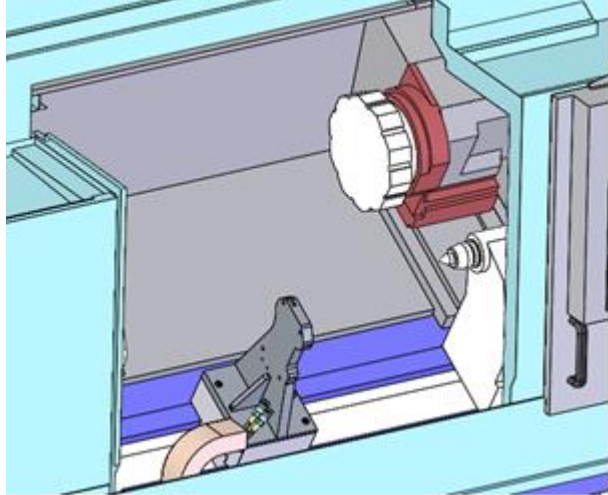
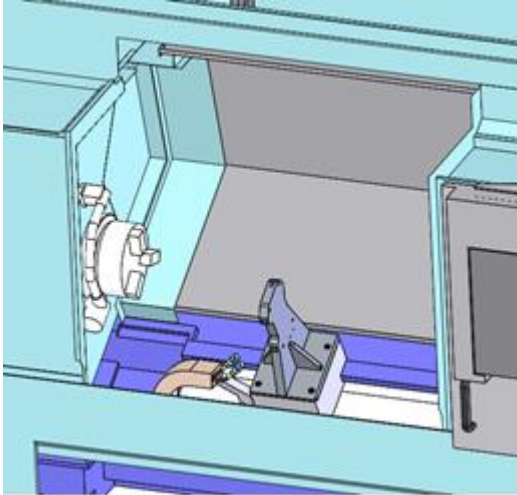

5.6. Rinsing the hydraulic system

In order to reduce the risk of particles entering the hydraulic system, connect the Steady Rest hydraulic hoses on the machine, and open the hydraulic directional valve for the Steady Rest. Then let the hydraulic oil flow through the filter of the hydraulic system to filter the oil before connecting the Steady Rest.

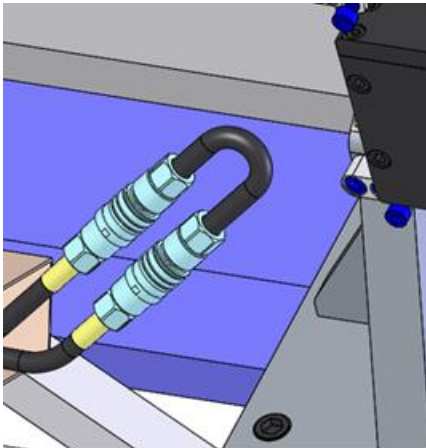

5.7. Lifting the Steady Rest

Mount the eye bolt into the lifting hole on the Steady Rest marked "LIFT", insert the lifting hook in the eye bolt and lift carefully, using for instance an overhead crane.

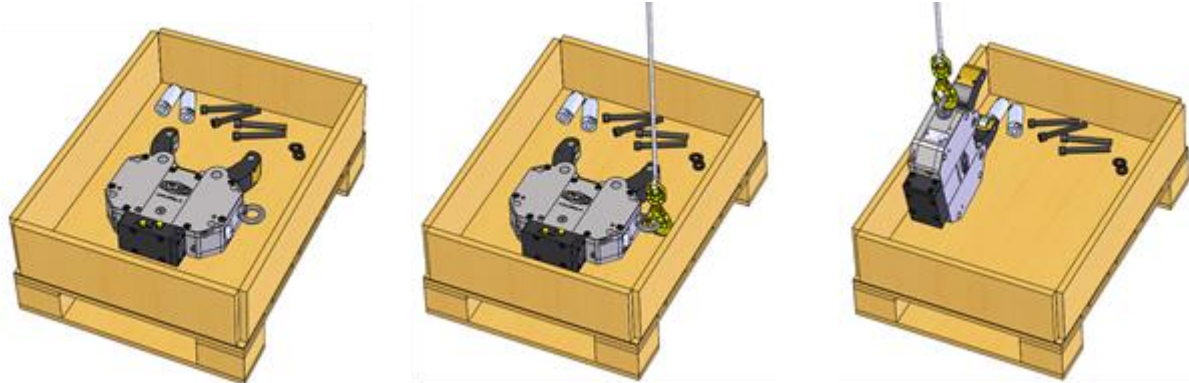

5.8. Mounting the Steady Rest on a bracket or an adapter plate

Lift the Steady Rest to the side of the bracket or adapter plate, and mount one of the mounting screws that fit the best (depending on the machine type) and tighten it light with your fingers.

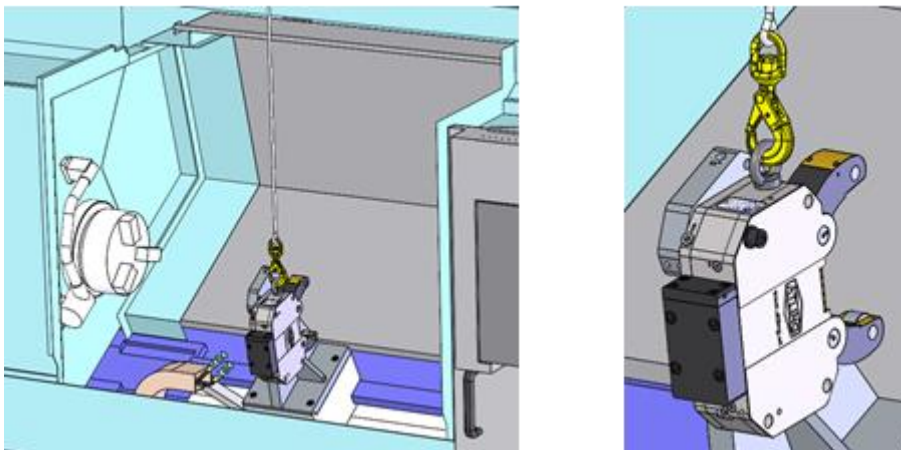

Then adjust the Steady Rest carefully, so that all mounting screws can be mounted and tighten them slightly.

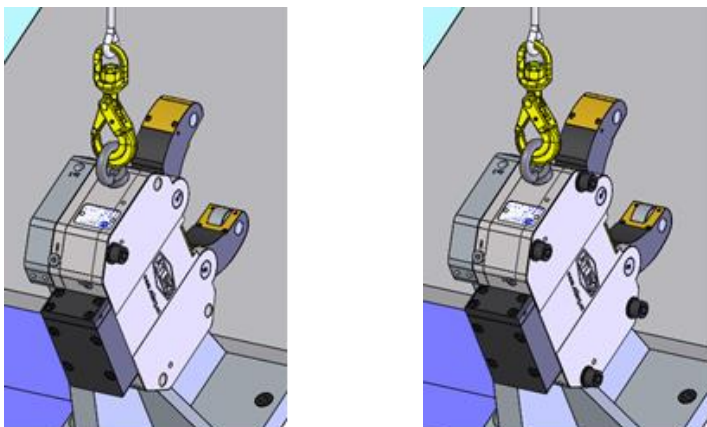

5.9. Mounting adjustment devices

Mount all the adjustment devices on the bracket/adapter plate, and tighten the adjustment device set screws. Also mount the adjustment screws, but keep a gap in relation to the Steady Rest.

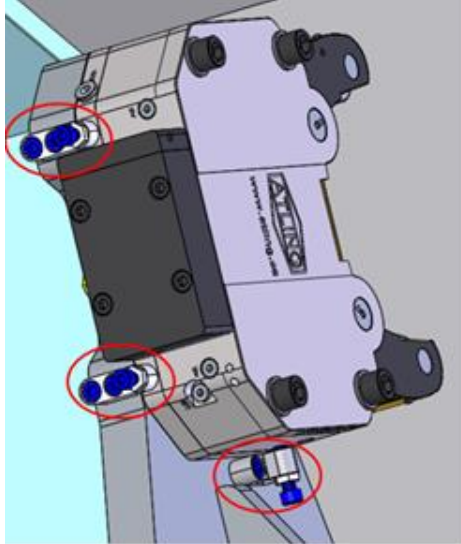
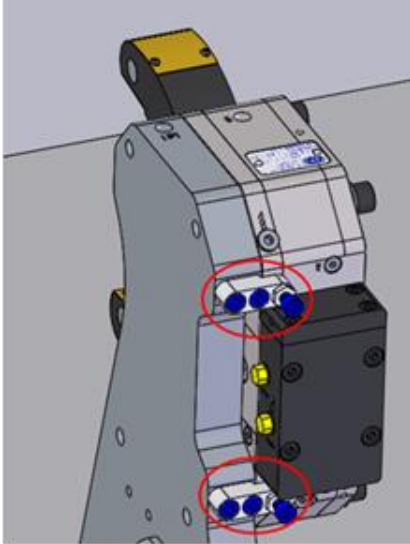

5.10. Connecting the hydraulics for opening and closing

Remove the protective plugs marked "Open" and "Close" from the Steady Rest...

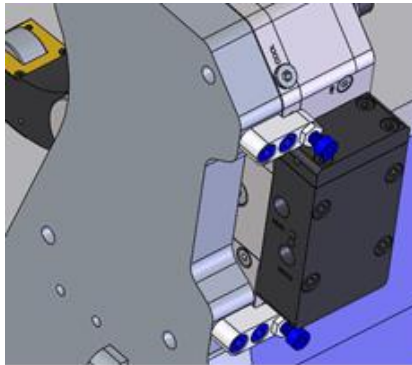
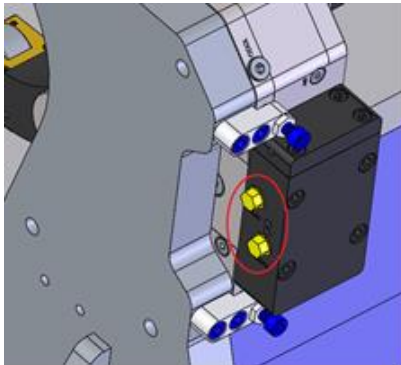

...and install the attached In-Line filters (Only for internal cylinder models) and also the necessary hoses and connections between the directional valve and Steady Rest.

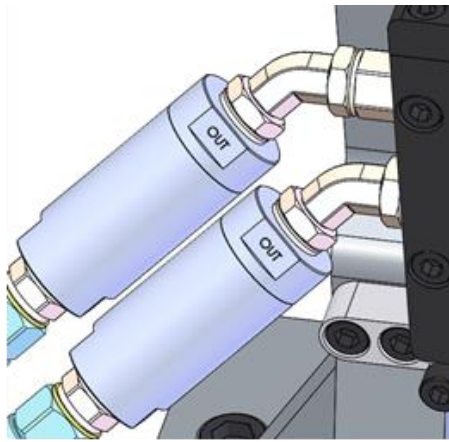
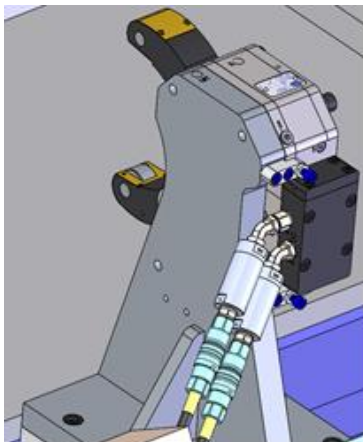

5.11. Hydraulic connection

Diagram of the hydraulic connections of the Steady Rest can be seen in Figure 5 and Figure 6. **Fel!**
Hittar inte referenskälla. below.

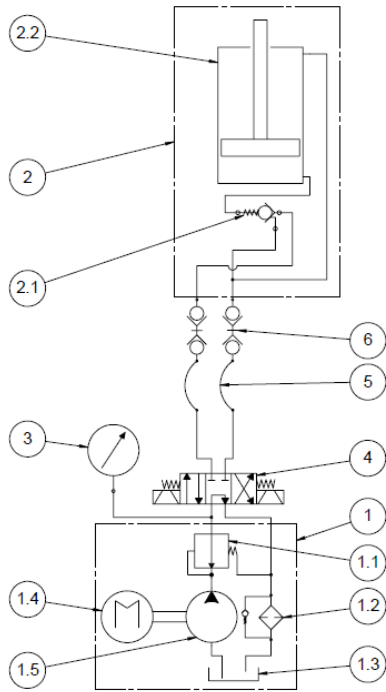

Hydraulic schematic External Cylinder

Pos.	Designation
1	Hydraulic unit
1.1	Pressure reducer
1.2	Oil filter (return to tank)
1.3	Oil tank
1.4	Motor
1.5	Hydraulic pump
2	Steady rest cylinder
2.1	Safety valve
2.2	Cylinder
3	Pressure Gauge
4	Directional valve (4/3)
5	Hose
6	Quick connection

Figure 5. Diagram of hydraulic connections of a Steady Rest with an external cylinder.

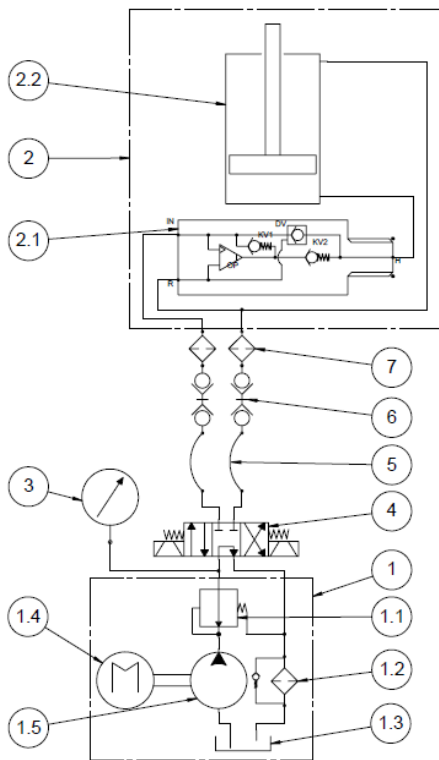

Hydraulic schematic Internal Cylinder

Pos.	Designation
1	Hydraulic unit
1.1	Pressure reducer
1.2	Oil filter (return to tank)
1.3	Oil tank
1.4	Motor
1.5	Hydraulic pump
2	Steady rest cylinder
2.1	Pressure Booster (incl. Safety valve)
2.2	Cylinder
3	Pressure Gauge
4	Directional valve (4/3)
5	Hose
6	Quick connection
7	In-Line Filter

Figure 6. Diagram of hydraulic connections of a Steady Rest with an internal cylinder

5.12. Coolant flush through levers

All Atling standard models can be connected to a coolant system to flush chips from the rollers. This is to prevent chips from getting in between the workpiece and the rollers, which may damage both of them. The coolant is connected via a 1/4" thread (1/8" AX1E/AN1E) on the back side of the Steady Rest. Recommended coolant pressure: 10–20 bar. Maximum pressure allowed: 70 bar.

5.13. Connecting coolant/cooling air

Remove the plug from the side of the cover marked "Cool"...

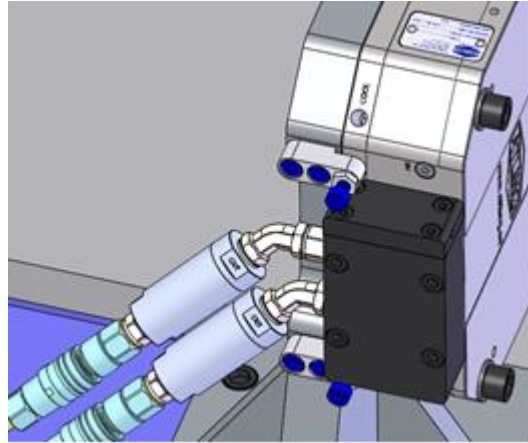
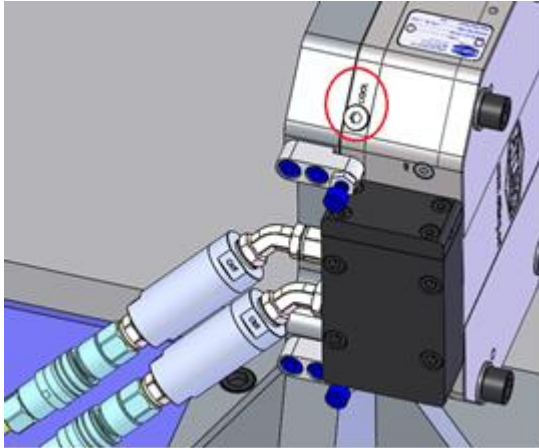

...and install the necessary hoses and connections for coolant fluid or cooling air.

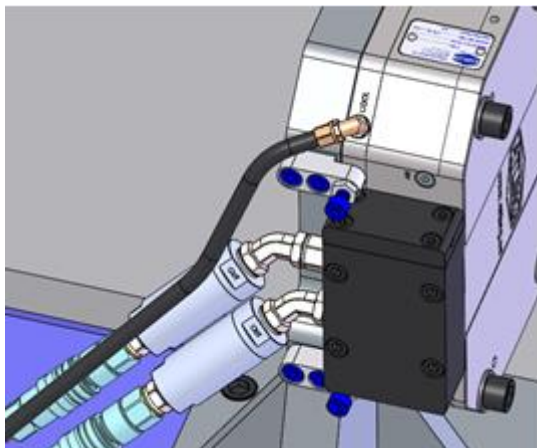

5.14. Lubrication connection (Automatic oil lubrication)

Remove the plug from the connection marked "LUB" on the back side of the Steady Rest housing...

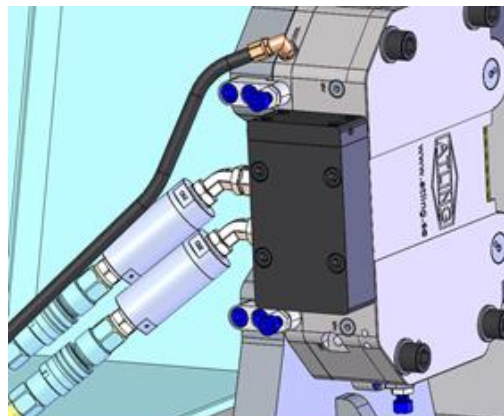
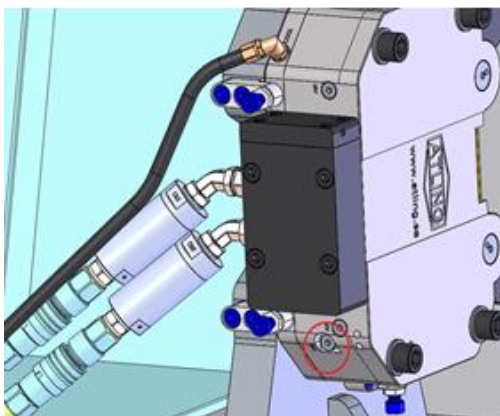

...and install the necessary hoses and connections for lubrication to the lubrication unit.

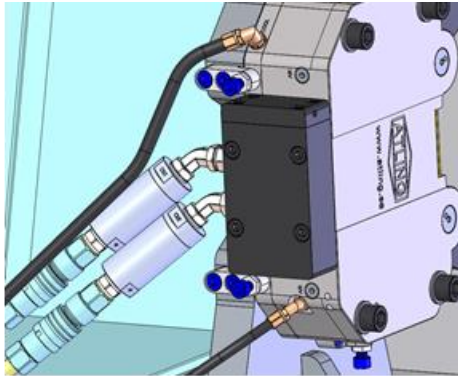

Lubrication oil unit: Pump pressure 12–45 bar, venting: Max 3 bar. Lubrication interval 3–5 minutes.

5.15. Connecting pneumatic over pressure

Remove one of the plugs marked "Air" on the back side of the housing, preferably the uppermost one...

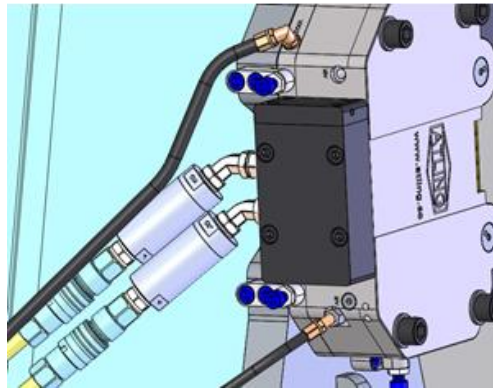
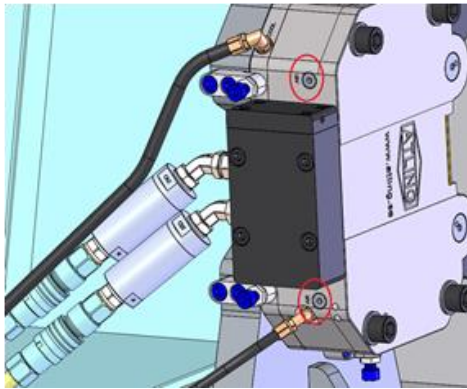

...and install the necessary hose and compressed air connection as a protective overpressure (0.5 bar). In some cases it is a good idea to install a small filter in the lower "Air" connection, or a short hose to avoid an increase of the protective pressure that may be a result of opening the Steady Rest. At the same time this can be used as a drainage if coolant fluid would enter the steady rest.

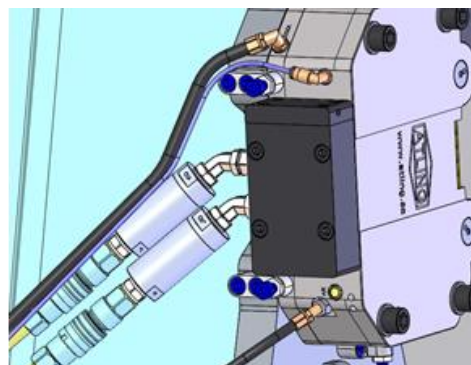
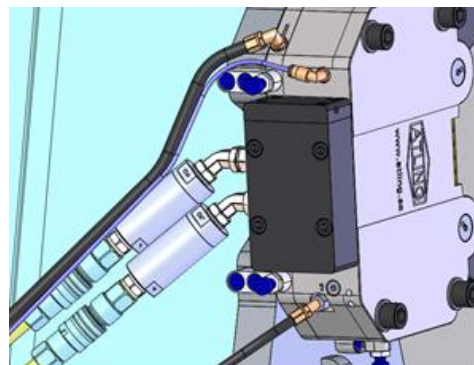

5.16. Installing inductive position indicators (External cylinder)

All of Atling's Steady Rests in the AXE, ASE and ANE series are ready to be used with two inductive position indicators. On the cylinder housing, there are two sets of threaded holes, M12x1 (AX1E=M8x1) (see Figure 1, position 10) for attaching the inductive sensors. It is possible to use two sensors to read two adjustable levels, or one sensor to read one selected level. In the latter case the sensor can be connected to the back or front connection. The measuring points are defined by the position of the nuts on the position indicator. The system is fully sealed, which improves the life span of the inductive sensors.

This is how to set the adjustable measuring points:

Remove the plug from the back side of the cylinder housing. Unscrew the outer nut on the position indicator, **Fel! Ogiltig självreferens i bokmärke.**, position 9) by using the designated special key, delivered with the Steady Rest. Adjust the inner nut to the desired position. Screw the first nut back into its desired position. Re-insert the plug.

The entire position indicator can be removed. This can be done when the Steady Rest is in its fully opened position. In this case, remove the small plug on the cover of the Steady Rest, Figure 7, position 5 and loosen a set screw, Figure 7, position 6 with an Allen key. Remove the plug on the back side of the cylinder housing and then remove the position indicator. This is also done with an Allen key.

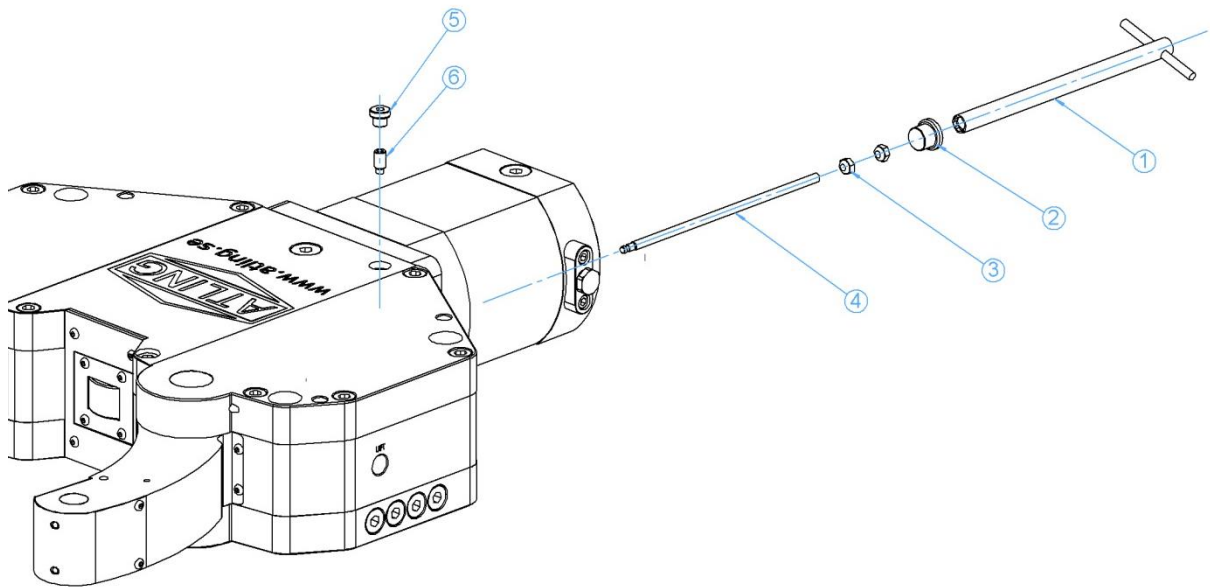

Figure 7. Exploded view of the position indicator system.

1 – Special key, 2 – Plug, 3 – Nut (2pcs), 4 – Threaded rod M6, 5 – Plug, 6 – Set screw

6. Centering the Steady Rest

6.1. Checking the straightness

Clamp a straight workpiece in the chuck with support from the tailstock and make sure it's completely round before starting the process of centering the Steady Rest.

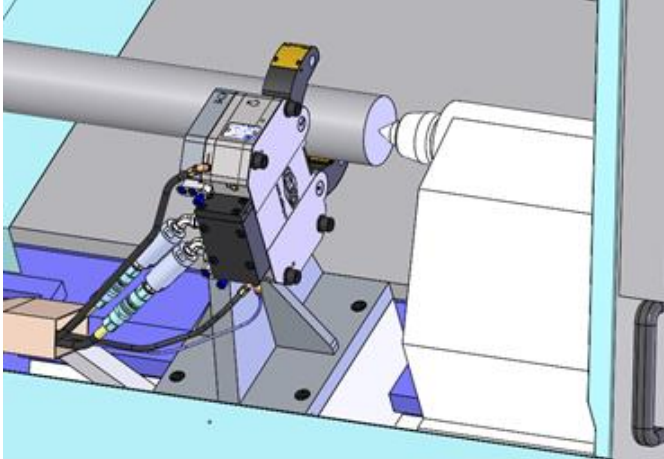

6.2. Mounting the gauges

Mount the two gauges according to the figure below; one of them straight in front of the Steady Rest and the other at a 90° angle to the other. This makes it easier to adjust the Steady Rest during the centring.

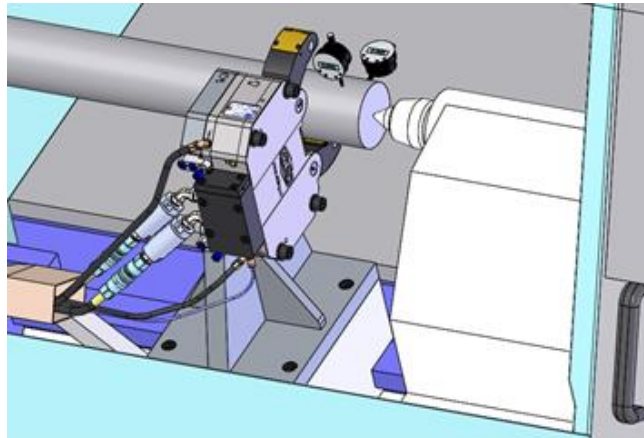
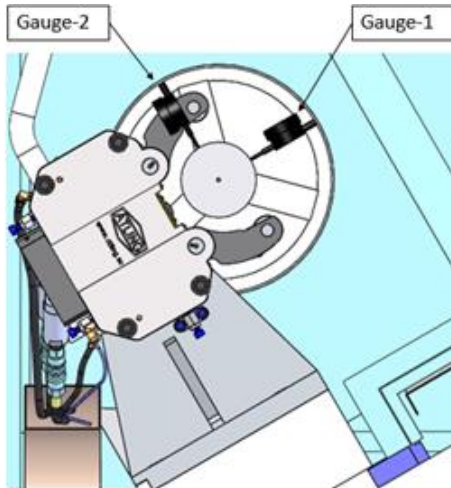

6.3. The first clamping with the Steady Rest

When clamping the workpiece for the first time, make sure the mounting screws and the adjustment screws are not too tight against the Steady Rest, so that it is possible for the Steady Rest to move. Clamp the workpiece with the Steady Rest and rotate the workpiece slowly. Tighten the adjustment screws little by little meanwhile you check how the gauges are affected. When the steady rest is centred, tighten the mounting screws.

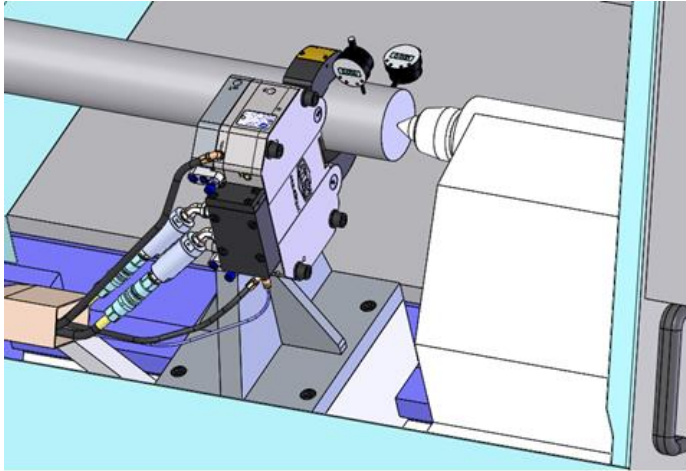

6.4. Removing the centre

Remove the tailstock from the workpiece, rotate the workpiece slightly and check again to see if the gauges are affected.

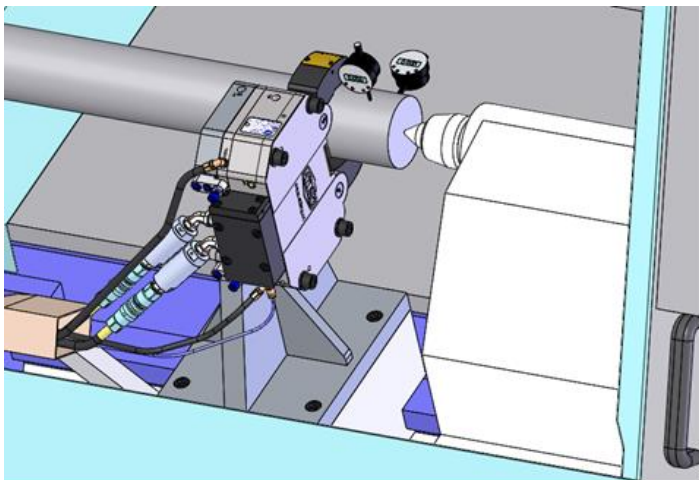

6.5. Adjusting the Steady Rest

When clamping the workpiece with the Steady Rest according to the description above, it is almost always necessary to adjust the Steady Rest further after the tailstock has been removed from the workpiece, because of the opposite conditions that apply regarding hanging and pressure. If the workpiece is heavy, it is almost always necessary to release the grip before making the adjustments. Sometimes it is necessary to carry out these steps several times to achieve an acceptable centering.

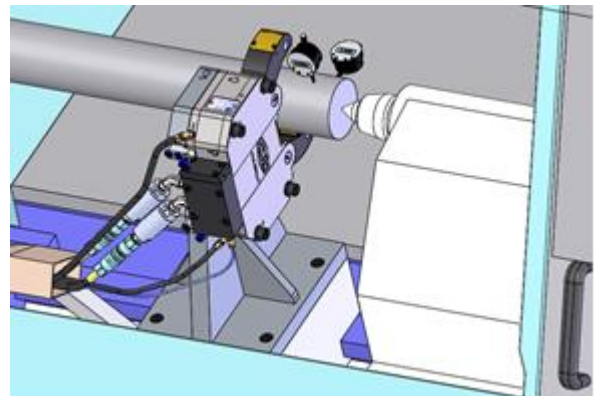
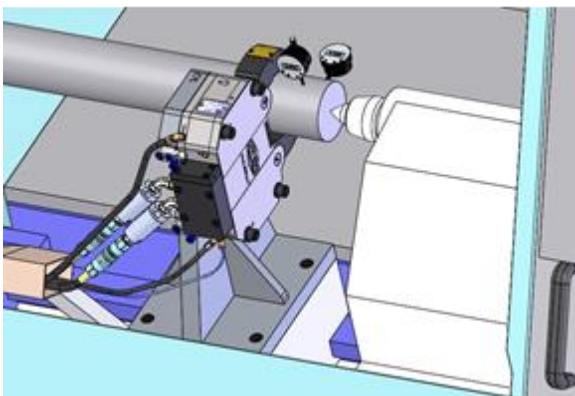



6.6. Conclusion

Note. A new adjustment may be necessary if the working pressure is changed.

- Clamp a carefully machined workpiece between to tailstocks. Check the wobbling of the shaft with a dial indicator. Replace the machined workpiece if the wobbling is unusually large.
- Then mount two dial indicators on the workpiece.
- Operate the cylinder with the selected operating pressure to close the Steady Rest, and to make the rollers close around the workpiece. Note. The Steady Rest must not be tightened to the bracket at this point.
- Use the gauges to check if the centre of rotation has moved. Depending on the accuracy of result aimed for, the change should be as small as possible.
- Tighten the set screws of the Steady Rest using a torque wrench. Open and close the Steady Rest once more. Check the gauges again.

6.7. Installing or replacing an extra opening lever

In Atling's AXE, ASE, ANE, AXI, and ASI series, it is possible to replace a track plate for levers (see position 3-1/3-2 in Exploded view – AXE, ASE page 30 and Exploded view – ANE page 31) to make them open extra wide. This feature can be installed on both levers, even at the same time. This can be ordered directly when buying a new Steady Rest but it can also be added later. To replace them, the Steady Rest must partly be disassembled. The plates are symmetrical in a way that makes it possible to use the same plate on either lever, just by turning it around 180 degrees.

6.8. Data table for installation

Model	Clamp \varnothing	Screw	Torque	Max pressure AS/AX models	Max pressure AN-models
Size	mm	mm	Nm	bar	bar
1	6-70	M10	40	25	15
2	8-105	M12	75	60	30
3	12-125	M12	75	60	30
4	12-160	M16	180	70	30
5	20-200	M16	180	70	-
6	30-255	M20	350	70	-
7	45-320	M20	350	70	-
8	85-360	M20	350	70	-
8.5	100-430	M24	600	60	-
8.7	140-470	M24	600	60	-
9	100-510	M24	600	60	-
10	250-680	M30	1100	60	-
11	450-870	M30	1100	60	-

Table 1, Shows the torque of screws and maximum hydraulic pressure for different Steady Rest models.

6.9. Pressure and clamping forces

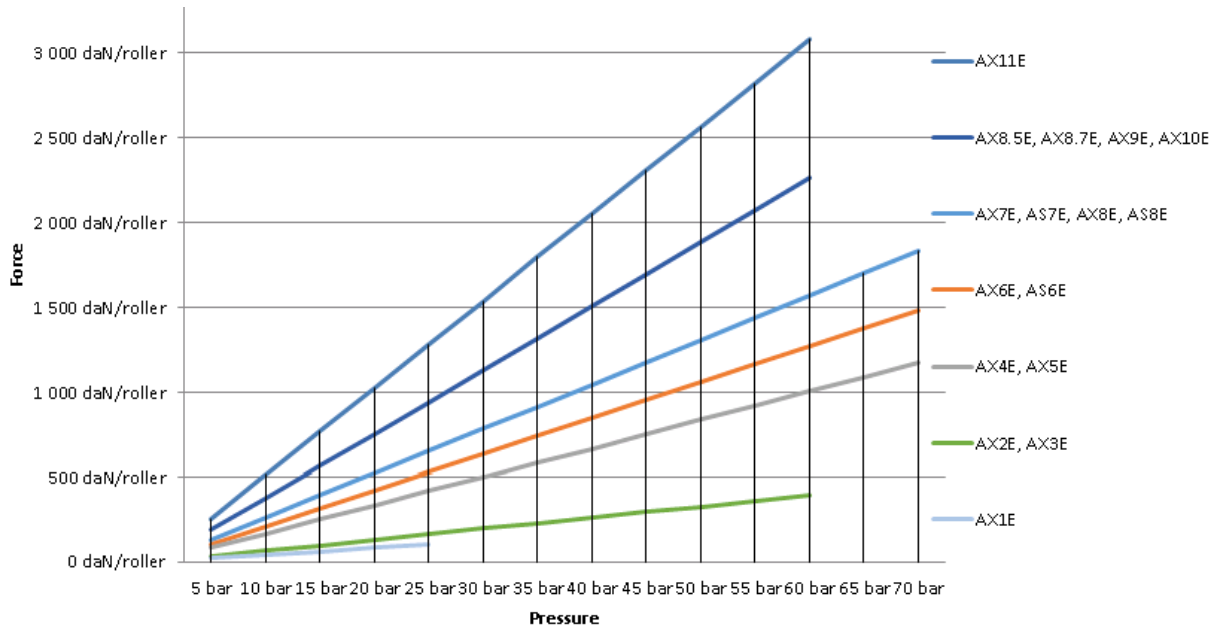

Table 2, Shows an approximate relation between pressure and clamping force for different Steady Rest models with external cylinder.

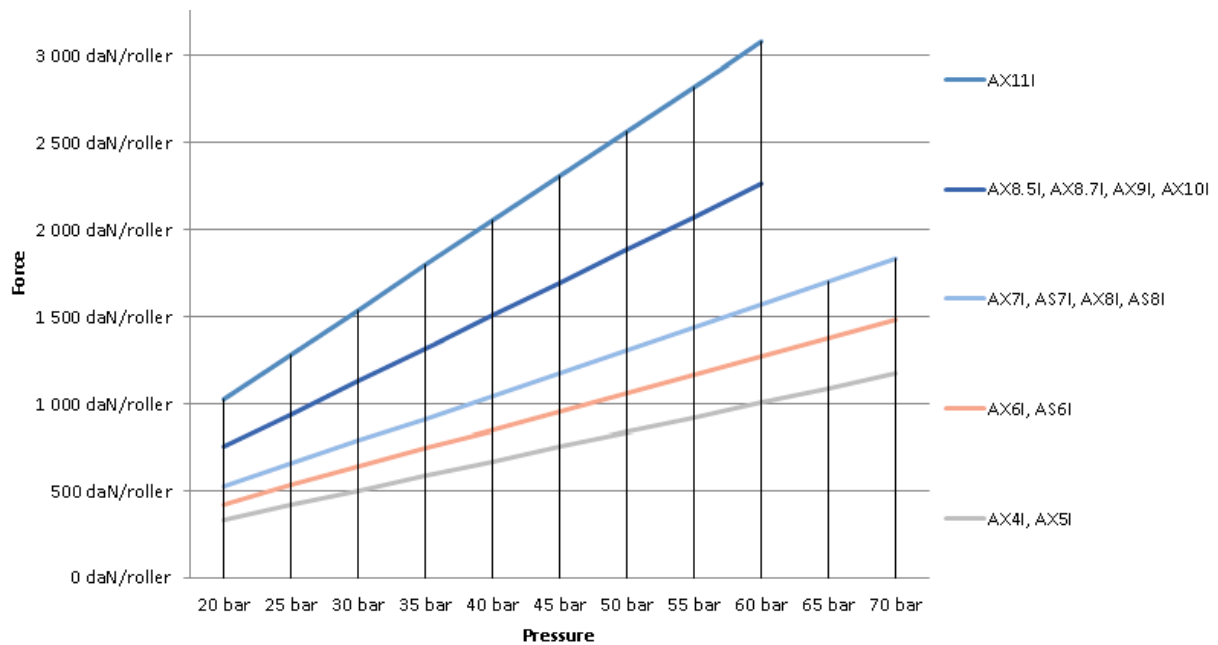

Table 3, Shows an approximate relation between pressure and clamping force for different Steady Rest models with internal cylinder.

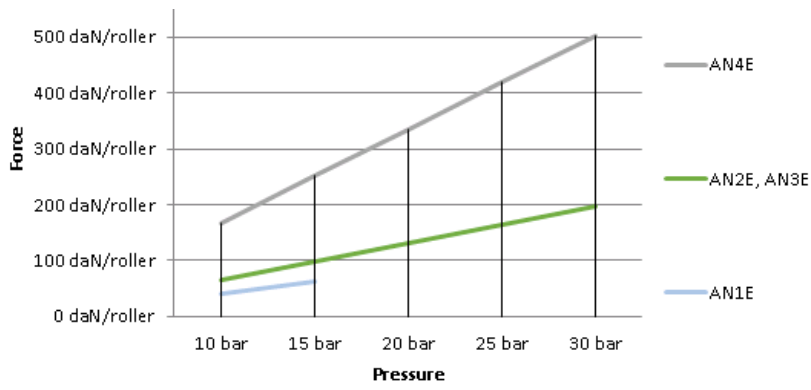

Table 4. Shows an approximate relation between pressure and clamping force for different Steady Rest of AN-models with external cylinder and thin levers.

7. Maintenance



Be careful when carrying out maintenance work on the Steady Rest. During maintenance the Steady Rest can not be operated and the hydraulic/pneumatic pressures must be disconnected to avoid personal injury. Make sure that the cylinder is pressureless when replacing the safety valve. Atlings recommend that comprehensive maintenance work should be carried out by the supplier or other trained staff.

7.1. Manual lubrication

The need for maintenance includes lubrication of the rollers and shafts on the rollers of both levers and middle piece. These are lubricated from the grease nipple. Note. No metering valves should be used for manual lubrication.

- Use a grease gun with the recommended grease type, DIN 51825-1 to 3 for normal loads. Grease the Steady Rest using the grease nipple with 3–6 hour intervals or more, depending on the work load.
- When greasing, push out the old grease with new.

7.2. Central lubrication

- Check daily to see that lubricating oil is output from all three rollers and the middle piece. The recommended lubrication interval is 3–5 minutes.

7.3. Other maintenance work

- Check the torque for the screw joints on the Steady Rest, 1–3 times per year, depending on usage.
- Visually check for leakage from the cylinder once a week.
- Check the rollers by rolling them and see if there is some play. Replace if necessary.
- Check the safety valve at least once a year. Check the valve by switching the pressure on and off. If the Steady Rest loses pressure, the safety valve is faulty. This must be fixed immediately.
- Carry out an annual overhaul (lift the cover, replace any damaged parts, clean all components and lubricate them).
- Carry out daily checks of both wipers and seals. Replace the wipers and seals if necessary.

7.4. Replacing the rollers and middle piece wiper

Disassembly is carried out in the following order according to Figure 8.

- Loosen the screws (No 33-1) that holds the wiper
- Remove the wiper (No 31) by pulling it straight out
- Loosen the set screw (No 18) that locks the stub shaft in the middle piece
- Carefully tap out the stub shaft (No 8) with a brass mandrel or use an extractor
- Remove the roller (No 10)

Assemble in the reverse order with a new roller and possibly a new wiper. Check to see that the roller can rotate after mounting the wiper; otherwise adjust the wiper.

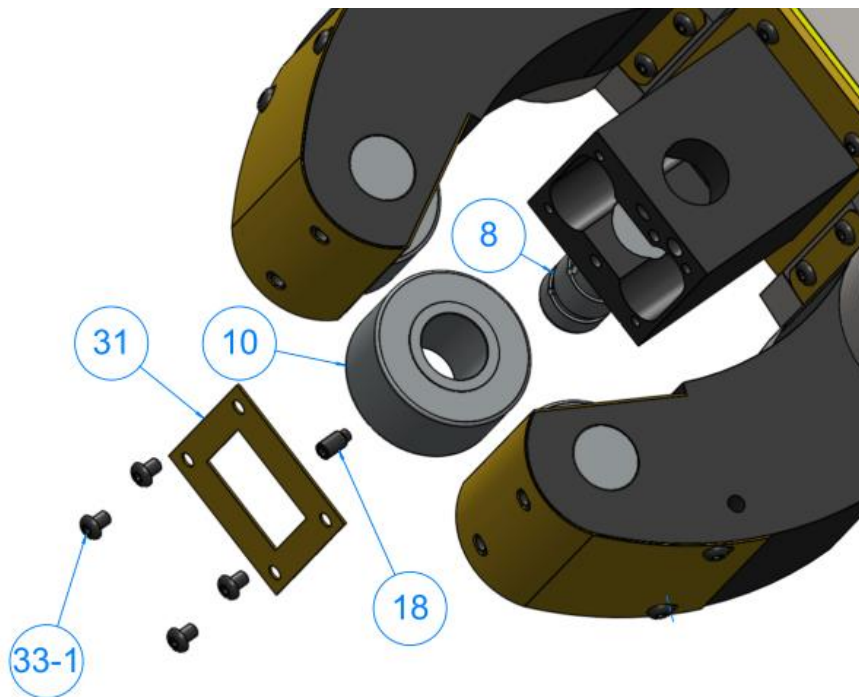

Figure 8. Middle piece and roller disassembly drawing

7.5. Replacing the rollers and lever wiper

Disassembly is carried out in the following order according to **Fel! Hittar inte referenskälla..**

- Loosen the screws (No 22 and 33) that hold the wiper
- Remove the wiper (No 32) by carefully pull it out.
- Loosen the set screw (No 18) that locks the stub shaft in the lever
- Carefully tap out the stub shaft (No 8) with a brass mandrel or use an extractor, for instance Atlings special extractor.
- Remove the roller (No 10)

Assemble in the reverse order with a new roller and possibly a new wiper. Check to see that the roller rotates after mounting the wiper, otherwise adjust the wiper.

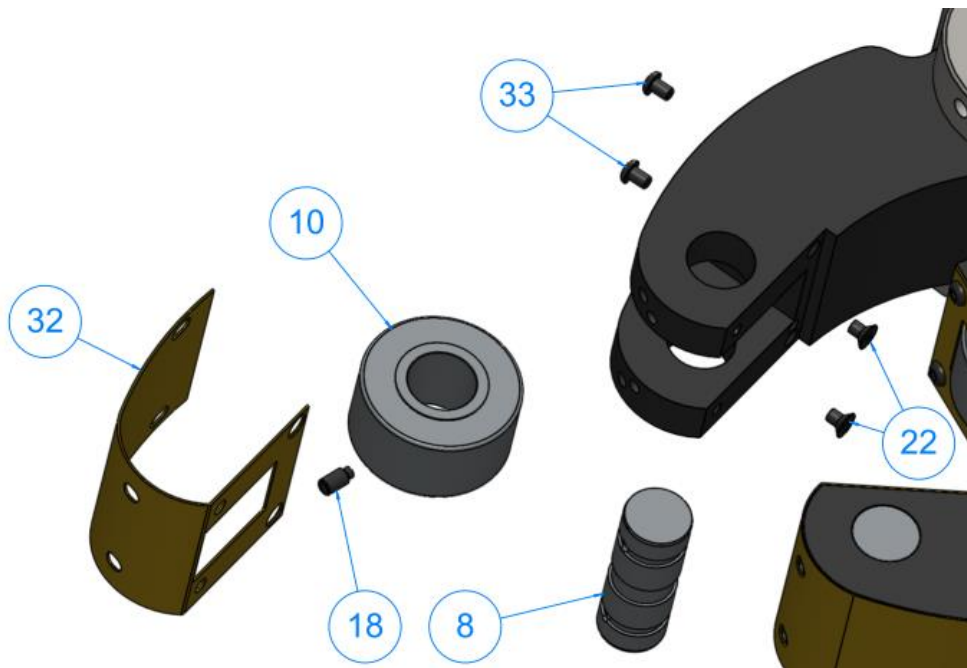

Figure 9. Lever and roller disassembly drawing

7.6. Removing cylinder (external cylinder)

To replace the cylinder gaskets, the cylinder needs to be removed from the machine. Remember to run the cylinder to its rear-most position (the levers of the Steady Rest must be as widely open as possible). It is advisable to empty the cylinder of hydraulic oil using, for instance compressed air before removing the cylinder. Then remove the cylinder following the steps below:

Start by removing the large plug on the cover of the Steady Rest (Figure 9, position 1). Under the plug there is a pin (Figure 10, position 2) with a threaded hole. Remove the pin with for example a slide hammer. Loosen the four screws (Figure 10, position 3). Now both the piston and the cylinder housing can be removed by pulling the cylinder backwards.

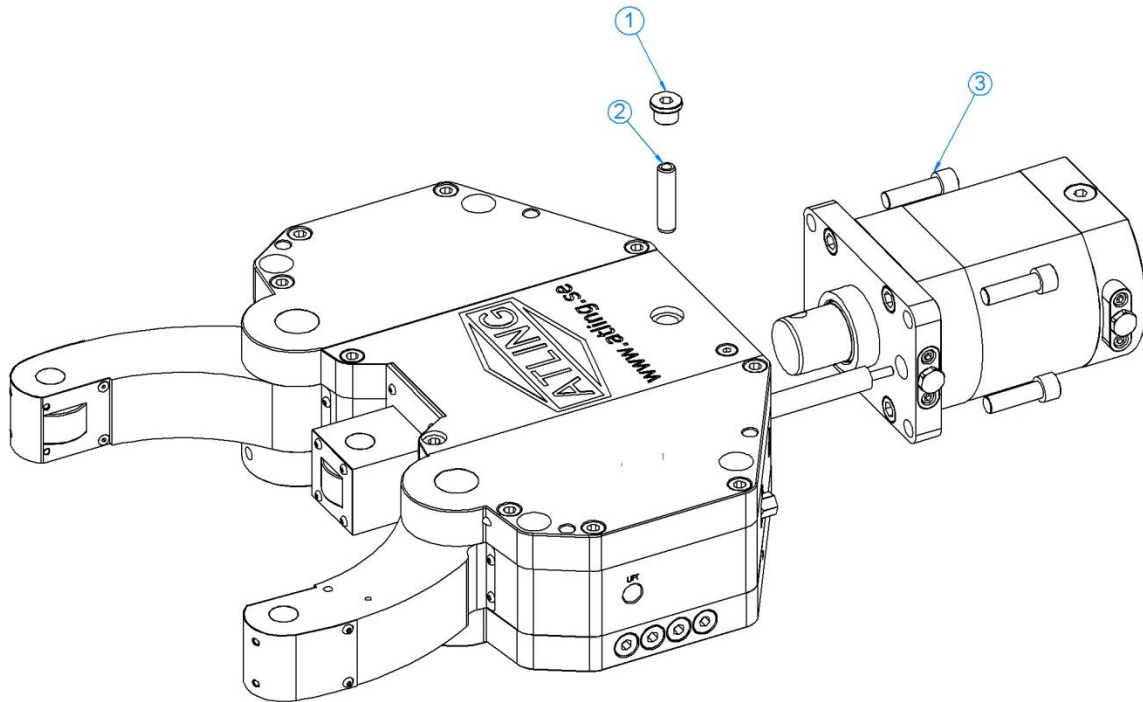
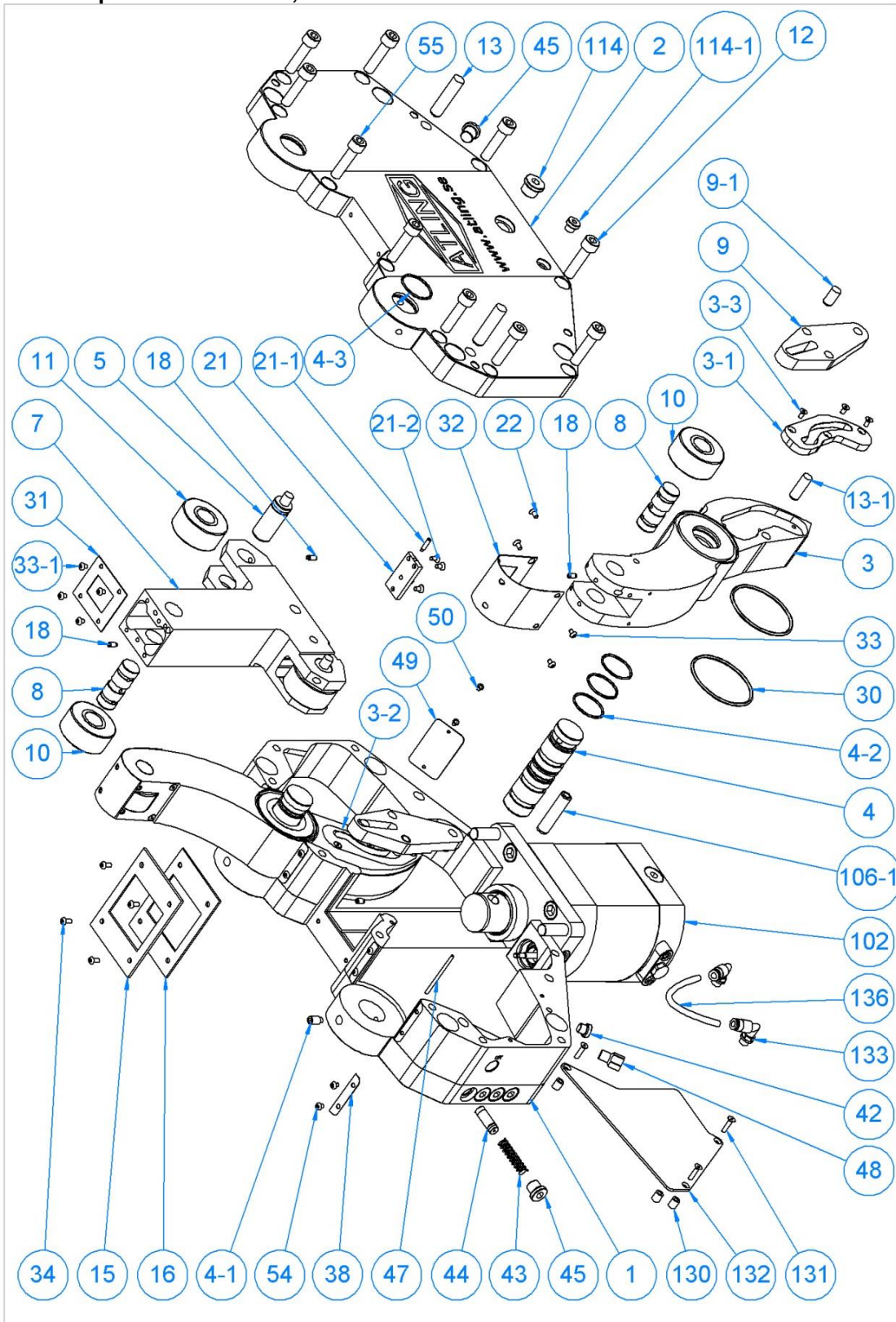

Figure 10. External cylinder disassembly drawing

8. Spare parts

8.1. Exploded view – AXE, ASE



8.2. Exploded view – ANE

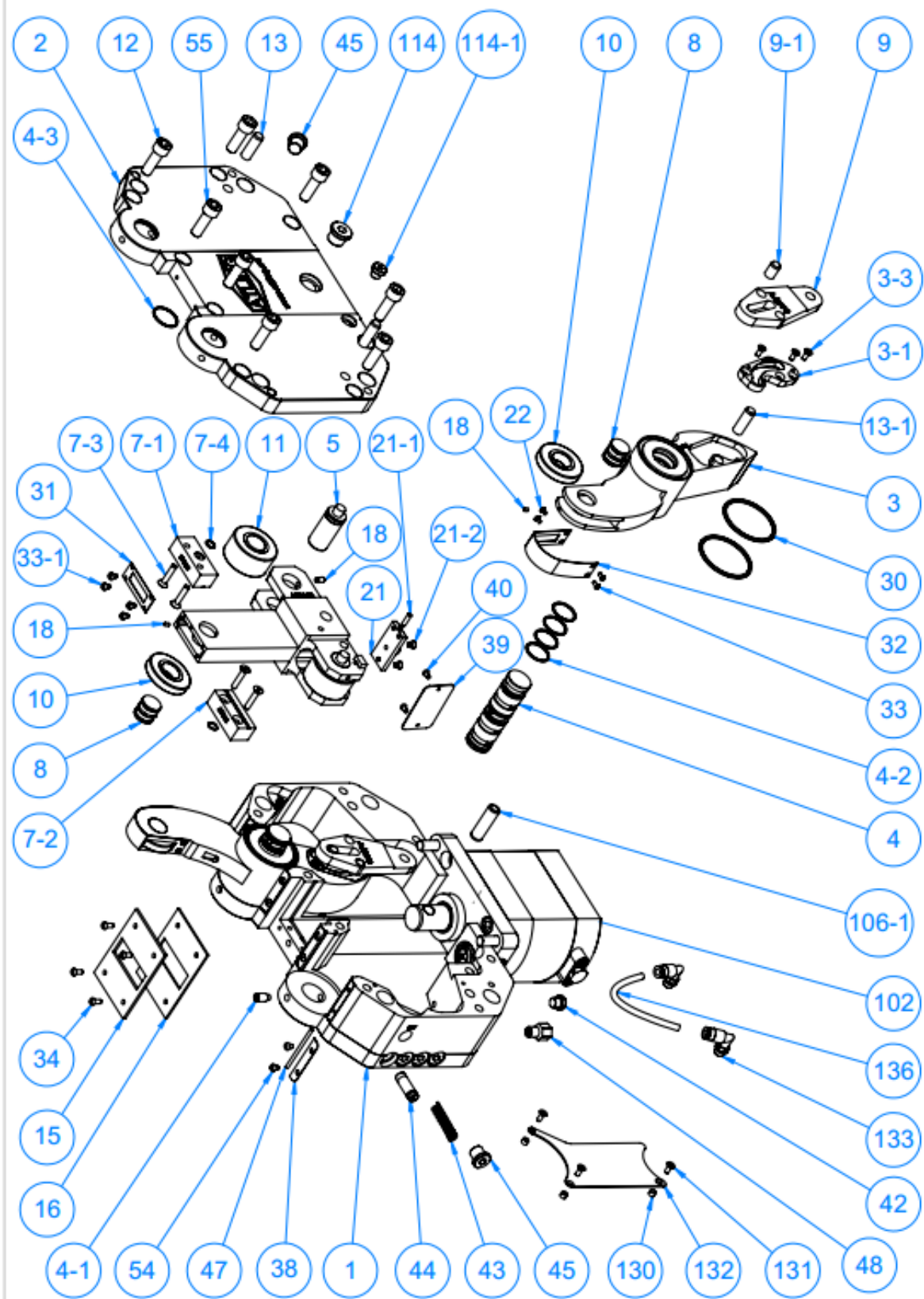

8.3. Exploded view – Cylinder AXE, ASE, ANE

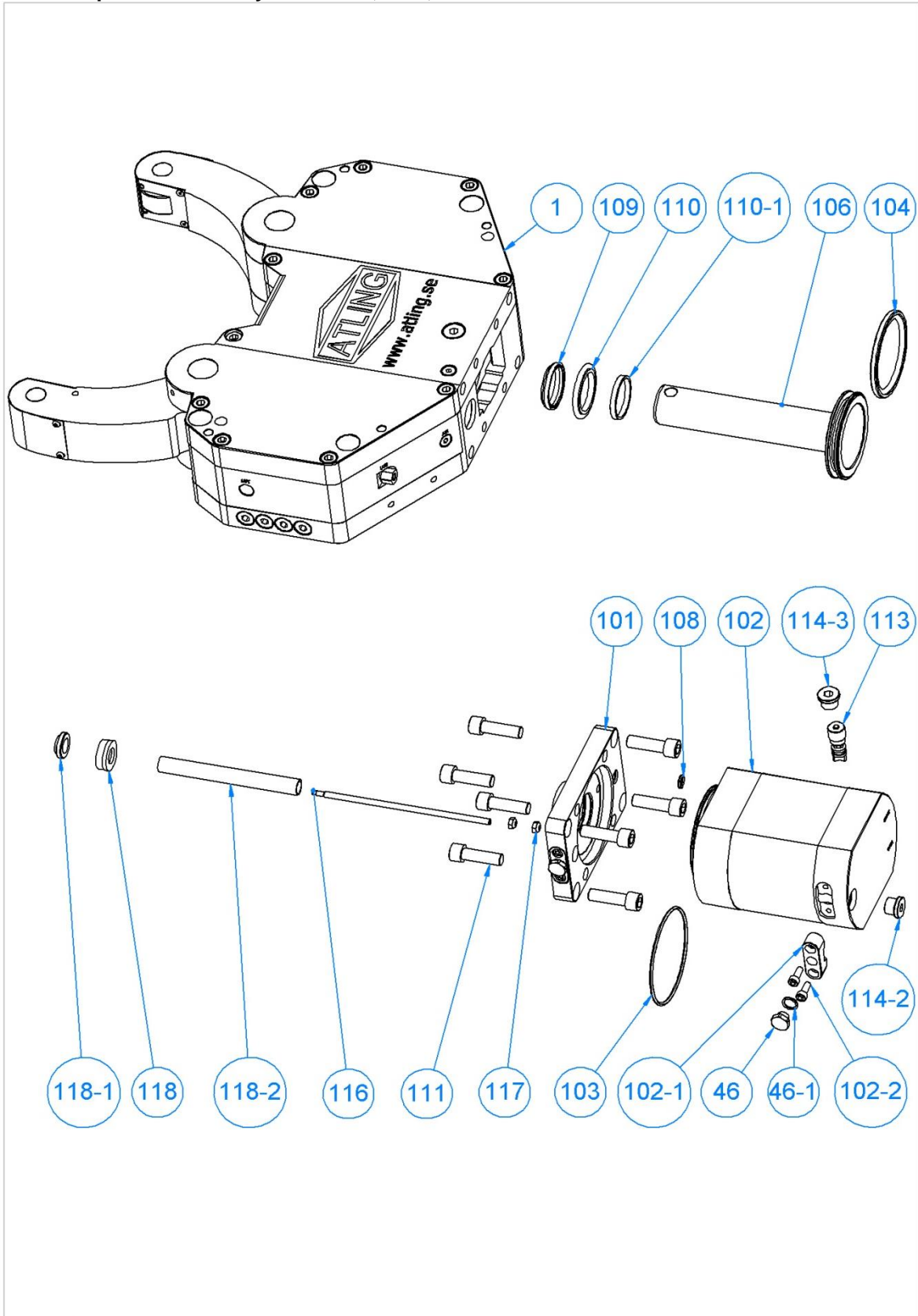



8.4. Exploded view – AXI, ASI

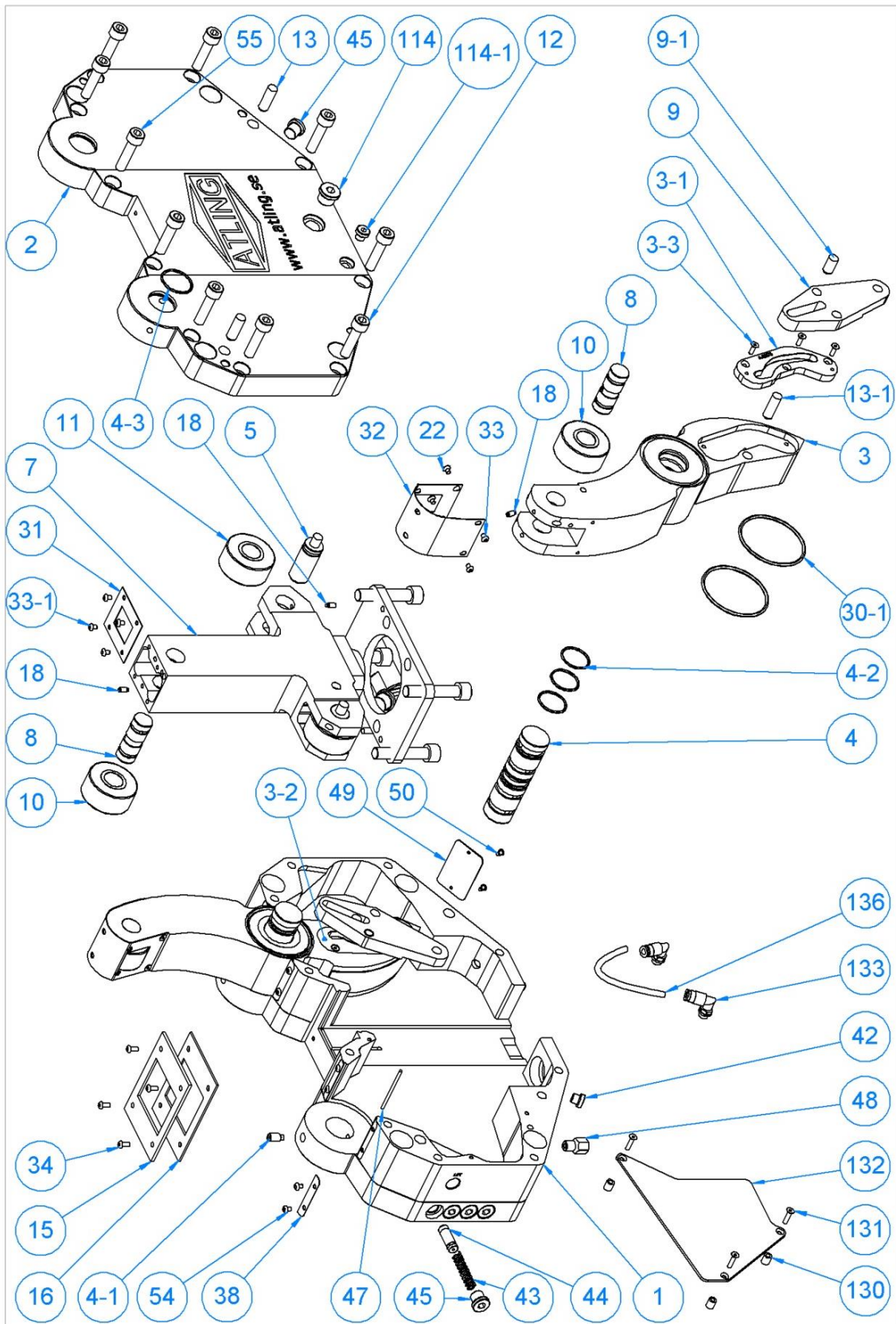

www.atling.se

Spare parts for the AXi version
of steadyrest

Sheet 1 of 2

8.5. Exploded view – Cylinder AXI, ASI

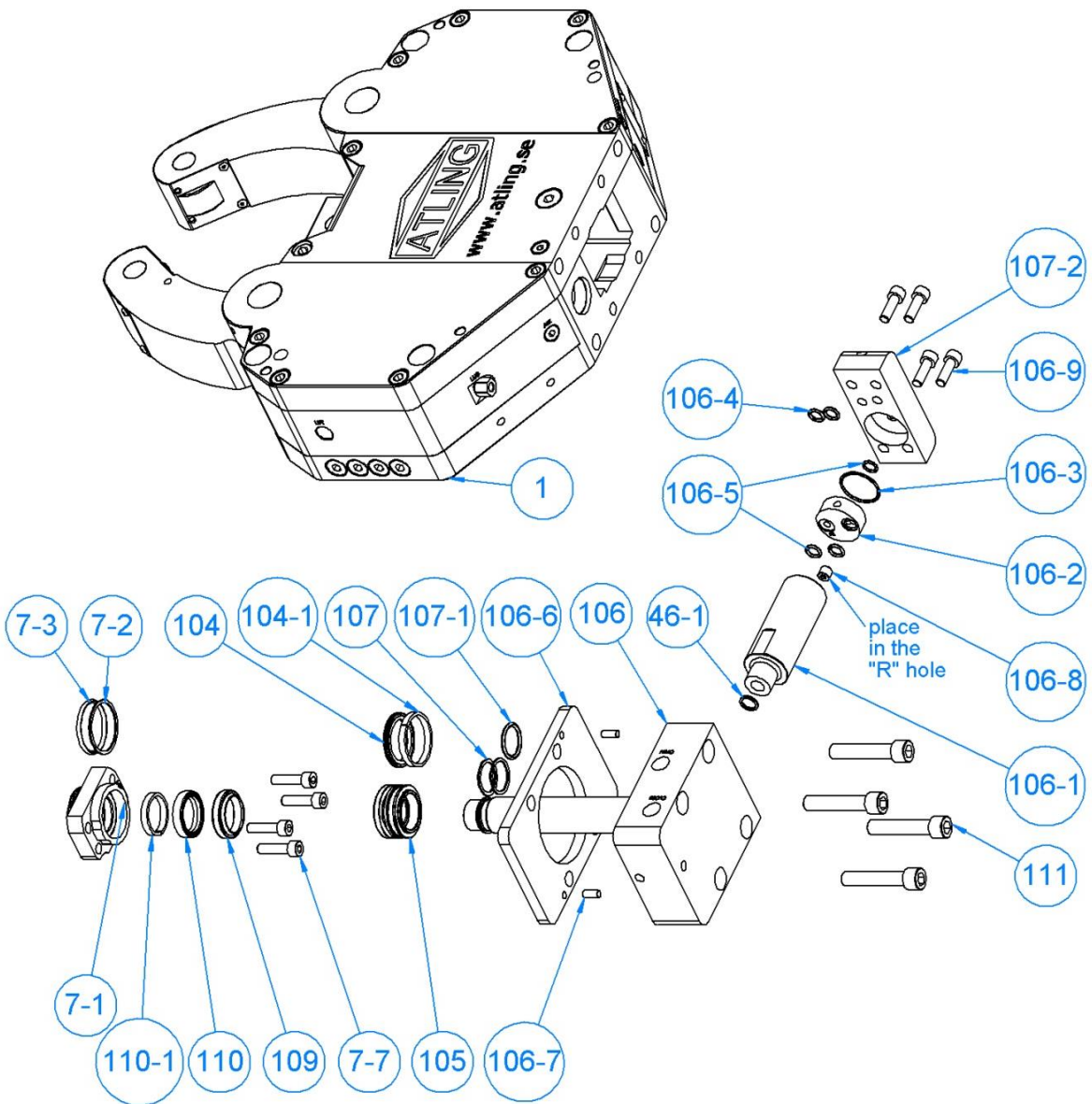



8.6. Spare kit part number

Steady rest	Seal kit House	Seal kit Cylinder	Wipers kit	Rollers kit	Shafts kit
AX1E	A5550101	A5550102	A5550103	A5550104	A5550105
AN1E	A550101	A5550102	A550103	A550104	A550105
AX2E	A5550201	A5550202	A5550203	A5550204	A5550205
A2E	A550201	A5550202	A550203	A550204	A550205
AX3E	A5550301	A5550302	A5550303	A5550304	A5550305
A3E	A550301	A5550302	A550303	A550204	A550205
AX4E	A5550401	A5550402	A5550403	A5550404	A5550405
AX4I	A5550401	A5550412	A5550403	A5550404	A5550405
A4E	A550401	A5550402	A550403	A550404	A550405
AX5E	A5550501	A5550502	A5550503	A5550504	A5550505
AX5I	A5550501	A5550512	A5550503	A5550504	A5550505
AX6E/AS6E	A5550601	A5550602	A5550603	A5550604	A5550605
AX6I/AS6I	A5550601	A5550612	A5550603	A5550604	A5550605
AX7E/AS7E	A5550701	A5550702	A5550703	A5550704	A5550705
AX7I/AS7I	A5550701	A5550712	A5550703	A5550704	A5550705
AX8E/AS8E	A5550801	A5550802	A5550803	A5550804	A5550805
AX8I/AS8I	A5550801	A5550812	A5550803	A5550804	A5550805
AX8.5E	A5550901	A5550902	A5550903	A5550904	A5550905
AX8.5I	A5550901	A5550912	A5550903	A5550904	A5550905
AX8.7E	A5550901	A5550902	A5550903	A5550904	A5550905
AX8.7I	A5550901	A5550912	A5550903	A5550904	A5550905
AX9E	A5550901	A5550902	A5550903	A5550904	A5550905
AX9I	A5550901	A5550912	A5550903	A5550904	A5550905
AX10E	A5551001	A5551002	A5551003	A5551004	A5551005
AX10I	A5551001	A5551012	A5551003	A5551004	A5551005
AX11E	A5551101	A5551102	A5551103	A5551104	A5551105
AX11I	A5551101	A5551112	A5551103	A5551104	A5551105

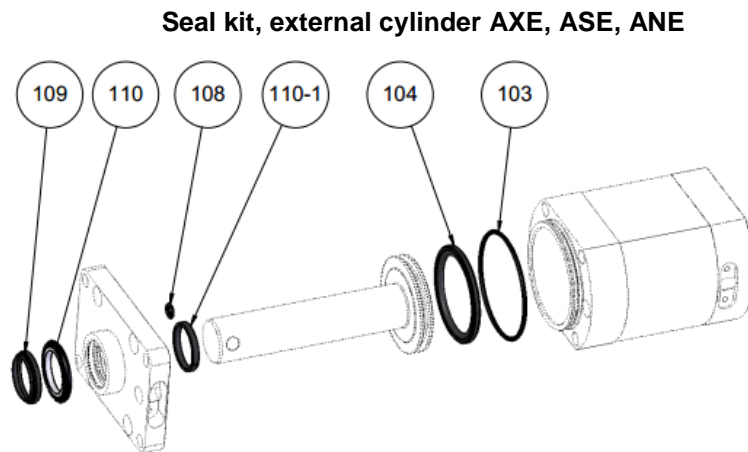
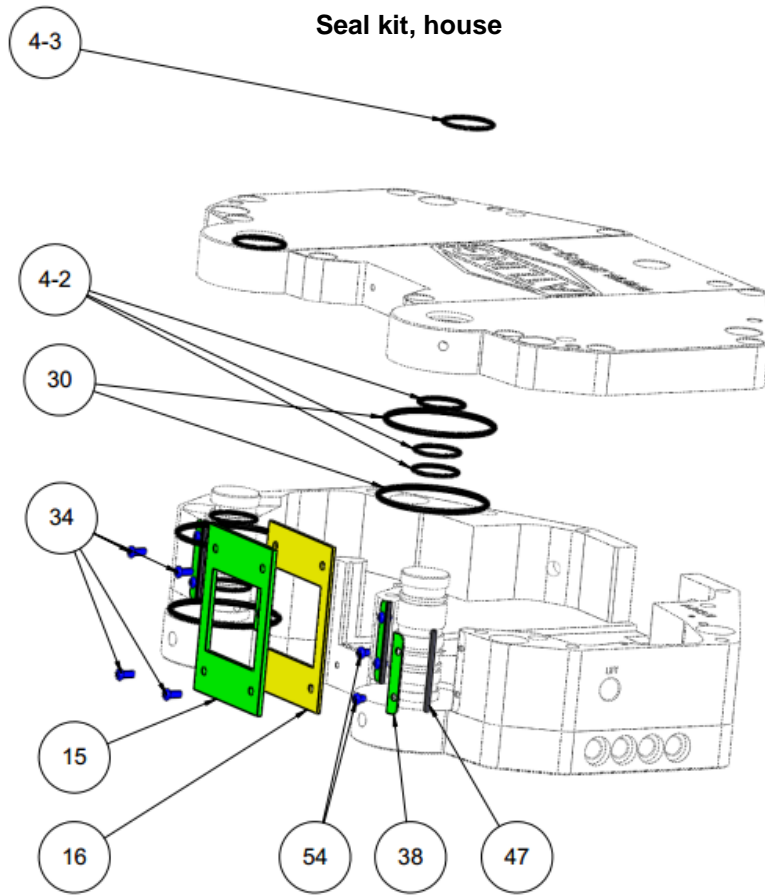

Seal kit, internal cylinder AXI, ASI

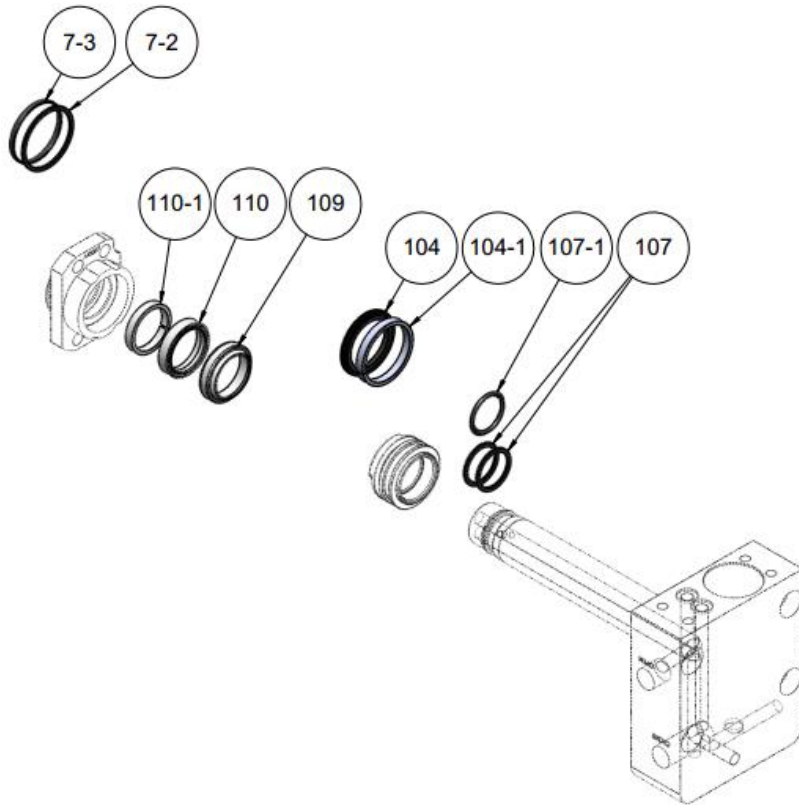

Wiper kit

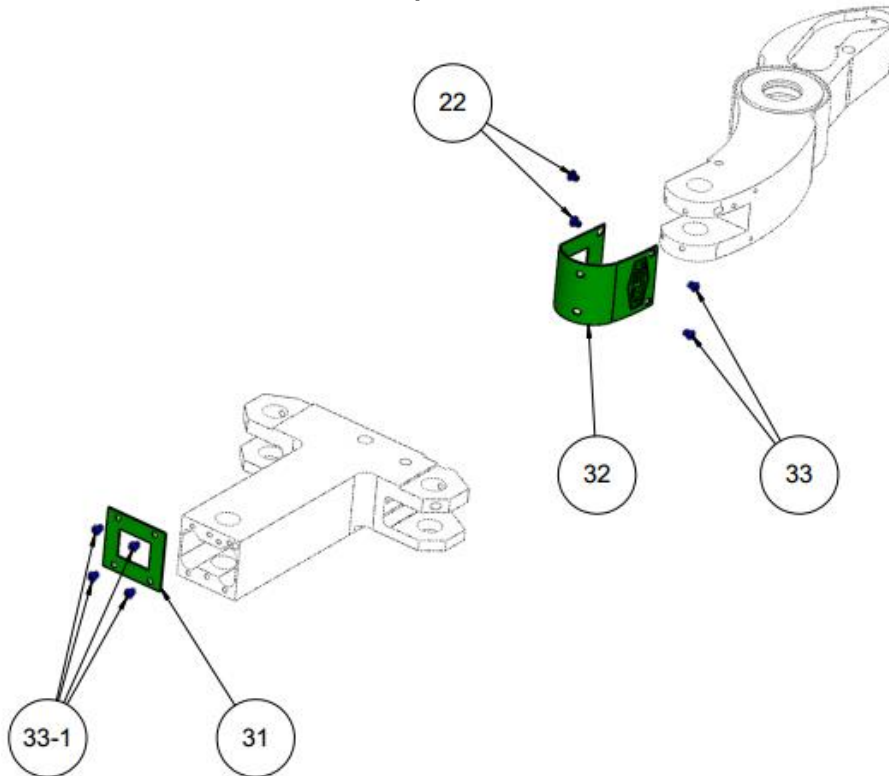

Roller kit

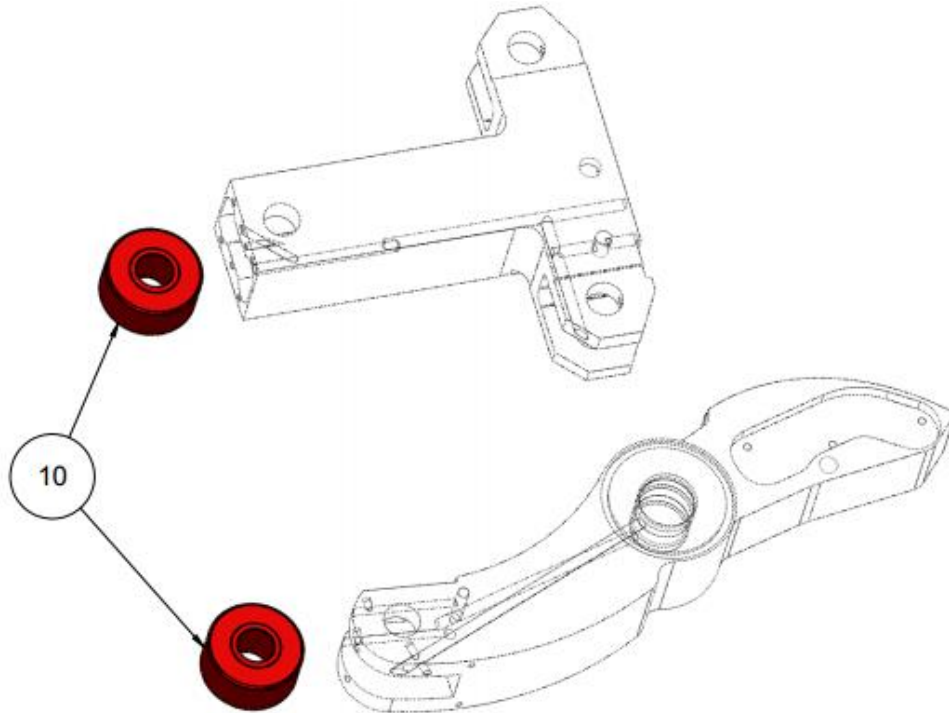

Shaft kit

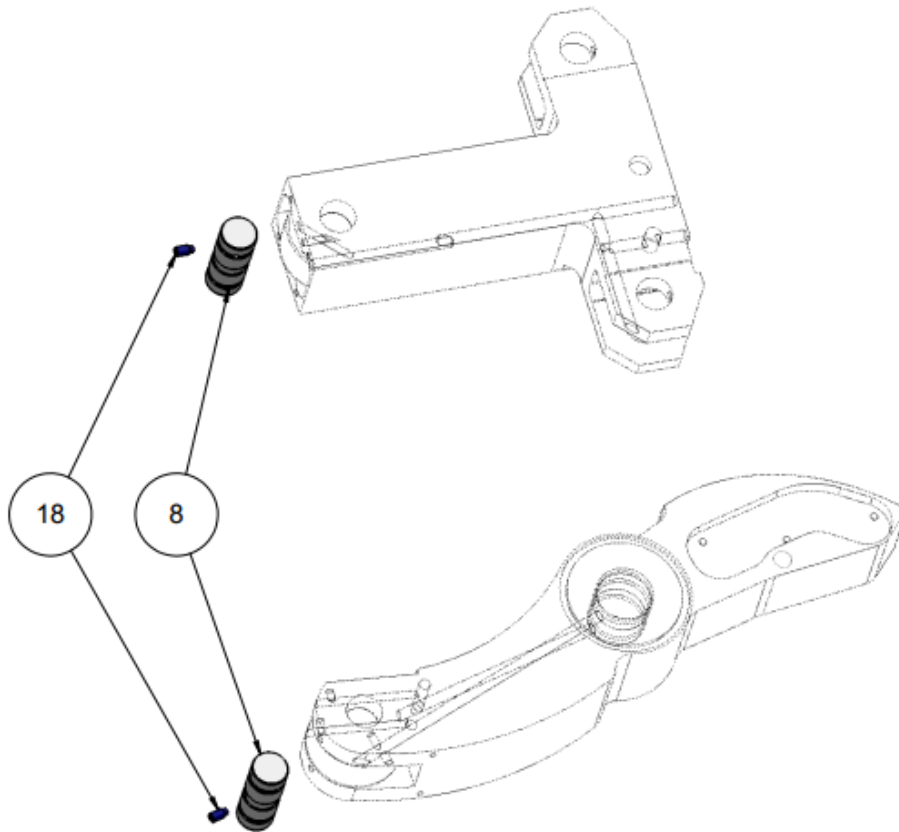



9. Notes

A series of horizontal dashed lines spanning the width of the page, providing a template for handwritten notes.