

DIMENSIONS - ANE

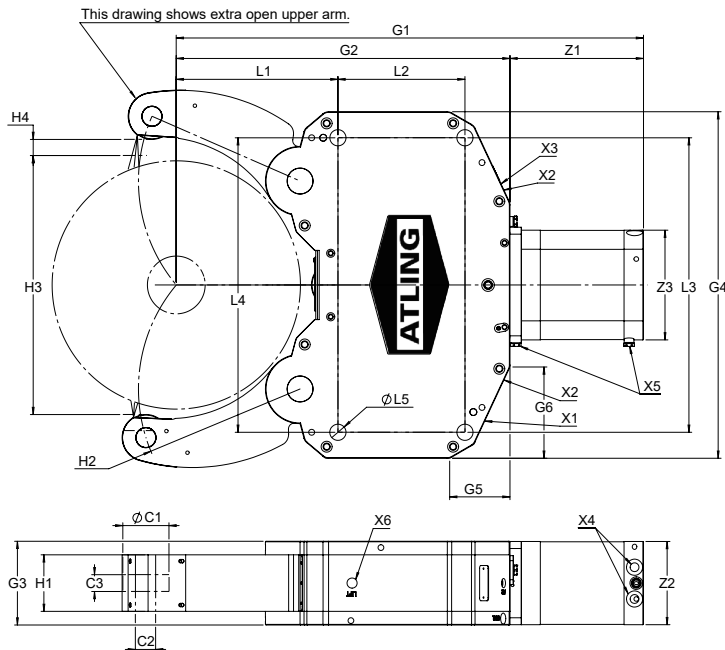

X1 - Central lubrication connection
G1/8"

X2 - Air barrier connection
G1/8"

X3 - Water flush connection
G1/4" (AN1E - G1/8")

X4 - Hydraulic Open/Close
G3/8" (AN1E - G1/4")

X5 - Stroke control thread
M12x1 (AN1E - M8x1)

Min operating pressure - 10 bar

Model size		AN1E	AN2E	AN3E	AN4E
Gripping range		6-70	8-105	12-125	12-160
Roller	(mm) C1	Ø24	Ø35	Ø35	Ø47
	(mm) C2	Ø8	Ø15	Ø15	Ø20
	(mm) C3	10	10	10	10
Lever	(mm) H1	19	19	19	19
	(mm) H2	R55	R75	R88	R116
	(mm) H3	75	110	128	168
	(mm) H4	5	2	8	10
Housing	(mm) G1	220	301	344	428
	(mm) G2	137	200	231	290
	(mm) G3	60	70	70	90
	(mm) G4	163	215	270	315
	(mm) G5	17	43	56	45
	(mm) G6	27	37	68	45
Hole pattern	(mm) L1	51	70	77	115
	(mm) L2	64	85	102	135
	(mm) L3	118	170	220	262
	(mm) L4	118	170	210	262
	(mm) L5	Ø11	Ø14	Ø14	Ø18
Cylinder	(mm) Z1	83	101	113	138
	(mm) Z2	60	70	70	89
	(mm) Z3	86	106	106	128
Lifting threads	(mm) X6	-	-	-	M16
Max gripping force/roller	(daN)	60	190	190	500
Max roller speed	(m/min)	730	930	930	805
Centering accuracy	(mm)	0,02	0,02	0,04	0,04
Repeatability	(mm)	0,005	0,005	0,005	0,005
Max operating pressure	(bar)	15	30	30	30
Weight	(kg)	8	17	23	45