

# DIMENSIONS - AXI

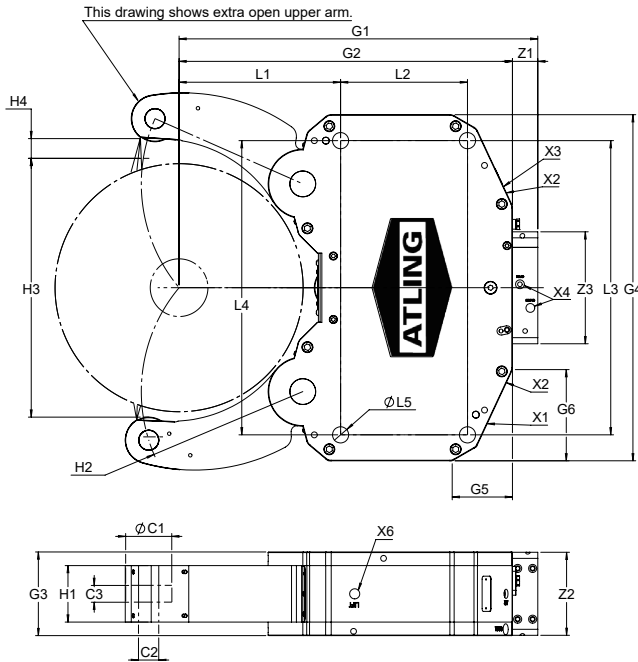

**X1** - Central lubrication connection  
G1/8"

**X2** - Air barrier connection  
G1/8"

**X3** - Water flush connection  
G1/4"

**X4** - Hydraulic Open/Close  
G3/8"

Min operating pressure - 20 bar

Model size		AX3I	AX4I	AX5I	AX6I	AX7I	AX8I	AX8.5I	AX8.7I	AX9I	AX9.5I	AX9.7I	AX10I	AX11I
Gripping range		12-125	12-160	20-200	30-255	45-320	85-360	100-430	140-470	100-510	340-600	360-620	250-680	450-870
Roller	(mm) C1	Ø35	Ø47	Ø52	Ø52	Ø62	Ø72	Ø80	Ø80	Ø80	Ø80	Ø80	Ø100	Ø160
	(mm) C2	Ø15	Ø20	Ø20	Ø20	Ø30	Ø30	Ø35	Ø35	Ø35	Ø35	Ø35	Ø45	Ø65
	(mm) C3	19	25	25	25	29	29	29	29	29	29	29	32	75
Lever	(mm) H1	37	53	53	53	68	68	98	98	98	98	98	98	118
	(mm) H2	R88	R116	R140	R168	R215	R235	R280	R300	R325	R370	R380	R430	R606
	(mm) H3	128	168	208	267	331	377	448	491	521	611	640	686	930
	(mm) H4	8	10	15	24	27	38	27	33	38	10,5	11	38	33
Housing	(mm) G1	344	334	368	434	509	537	622	647	705	731	744	847	1244
	(mm) G2	231	290	314	380	465	493	578	603	661	687	700	803	1200
	(mm) G3	70	90	90	110	145	145	145	145	145	145	145	165	198
	(mm) G4	270	315	315	438	500	500	600	600	700	670	670	760	1200
	(mm) G5	56	45	38	83	102	97	104	104	156	113	113	108	135
	(mm) G6	68	45	66	133	105	100	158	158	220	177	177	188	254
Hole pattern	(mm) L1	77	115	123	146	178	208,5	280	305,5	292,5	323	336	415	640
	(mm) L2	102	135	135	155	210	210	220	220	260	270	270	312	400
	(mm) L3	220	262	262	365	400	400	510	510	620	500	500	470	670
	(mm) L4	210	262	262	365	400	400	510	510	620	620	620	700	1100
	(mm) L5	Ø14	Ø18	Ø18	Ø23	Ø23	Ø23	Ø28	Ø28	Ø28	Ø28	Ø28	Ø35	Ø35
Cylinder	(mm) Z1	44	44	54	54	44	44	44	44	44	44	44	44	44
	(mm) Z2	70	89	89	109	144	144	144	144	144	145	145	144	197
	(mm) Z3	124	158	158	158	164	164	194	194	194	194	194	194	260
Lifting threads	(mm) X6	-	M16	M16	M16	M16	M20	M20	M20	M20	M20	M20	M24	M30
Max gripping force/roller	(daN)	390	1170	1170	1480	1830	1830	2260	2260	2260	2260	2260	2260	3070
Max roller speed	(m/min)	930	805	890	890	655	765	685	685	685	685	685	685	457
Centering accuracy	(mm)	0,04	0,04	0,06	0,06	0,06	0,06	0,06	0,06	0,10	0,10	0,10	0,10	0,20
Repeatability	(mm)	0,005	0,005	0,005	0,005	0,005	0,005	0,01	0,10	0,02	0,02	0,02	0,02	0,02
Max operating pressure	(bar)	60	70	70	70	70	70	60	60	60	60	60	60	60
Weight	(kg)	21	40	42	78	145	147	220	223	270	270	270	440	1360