



ATLING
STEADY
RESTS

QUALITY IN MIND

ATLING WAS FOUNDED by Gunnar Atling, an inventive quality manager from Stockholm, inspired by an idea of producing and selling riveters. Atling found a perfect location for his production in Ockelbo and started the business in 1947. Since then, much has happened. In 1973 we produced our very first steady rest and today our tools and machine parts play a central role in industries all over the world.

THE SPIRIT OF THE COMPANY is still the same and we still engineer and produce all our products in Ockelbo. But now, we also have a global network reaching more than 40 countries.

Accuracy combined with high-quality standards will always be the foundation of our production and we always try to find ways to improve our products, as well as our way of working.

SOMETIMES THE DISTANCE to success is minimal; a fraction of a millimeter, to be more precise. This is true for all our customers, where it's all about the details. To meet our customers' need for accuracy, we have carefully designed the Atling Steady Rest to hold and center work pieces with exact precision. This is one of the reasons why customers all over the world choose our steady rests for their work holding applications .



OUR STEADY RESTS

THE ATLING STEADY RESTS are used in many different industry sectors such as the automobile, aerospace, rail, energy, and the general manufacturing industry across the world.

All our steady rest series have their own special advantages, and the standard models covering a gripping range from 6 to 870 mm.

We also design and manufacture brackets and adapter plates to support installation of our steady rests in most machines.

Thanks to our solid experience we know how the industry works and what the requirements are, so we have created our standard products to suit most manufacturers. If you still need a customized solution, our design engineers will make sure to get you what you need.



CHOOSE A STEADY REST FROM ATLING

- » It is the most compact standard steady rest series in the world and will, thanks to the option of internal cylinder, fit any turning machine, even in the most critical space conditions.
- » It gives perfect support for heavy and long shaft turning.
- » Possibility to add extra open arm: upper, lower or both, keeping the same slim design and gripping range.
- » Flexibility to convert to extra open arm and external to internal cylinder.
- » Can be customized for your specific needs.
- » The Atling Zero Point Clamping Bracket drastically reduces the setup time
- » The standard series comes with a gripping range from 6 to 870 millimeters

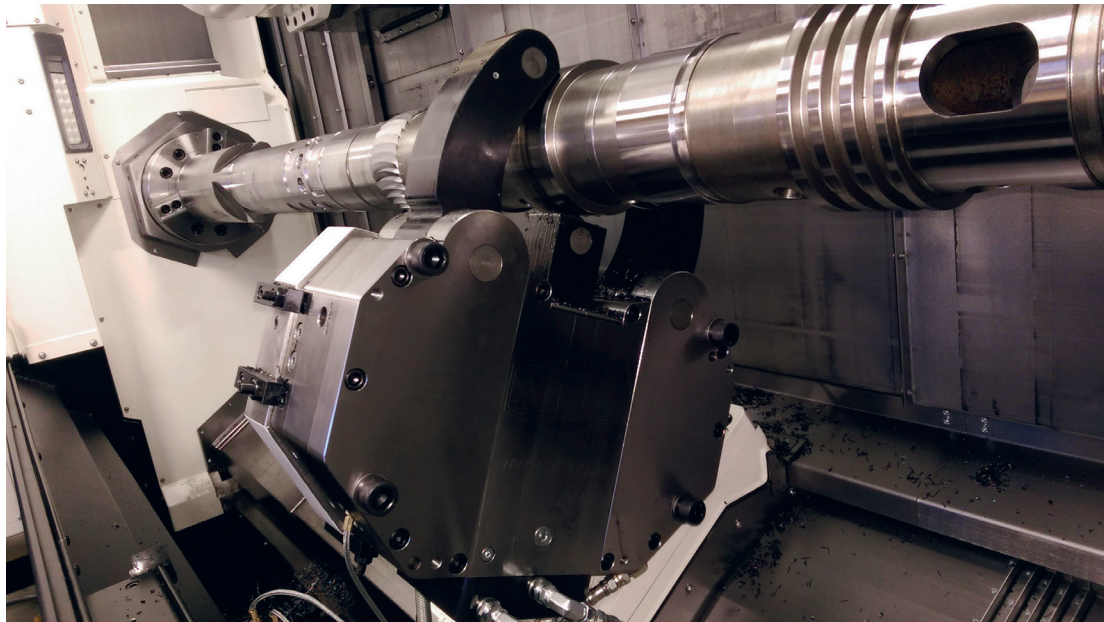

GRIPPING RANGE



» **Atling AX-series:**
Our standard range of self centering steady rests.

GRIPPING RANGE AX-SERIES (MM)

Model	AX1	AX2	AX3	AX4	AX5	AX6	AX7	AX8	AX8.5	AX8.7	AX9	AX9.5	AX9.7	AX10	AX11
Gripping range	6-70	8-105	12-125	12-160	20-200	30-255	45-320	85-360	100-430	140-470	100-510	340-600	360-620	250-680	450-870



» **Atling AS-series:**
Designed to fit hole patterns of other brands.

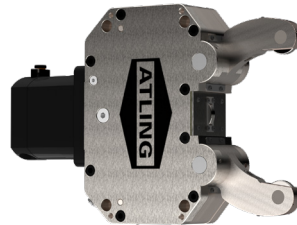

» **Atling AN-series:**
Our range of steady rests with narrow arms.

GRIPPING RANGE AS-SERIES (MM)

Model	AS6	AS7	AS8
Gripping range	30-255	45-320	85-360

GRIPPING RANGE AN-SERIES (MM)

Model	AN1	AN2	AN3	AN4
Gripping range	6-70	8-105	12-125	12-160

Order configuration code

AX/AS/AN: Model serie. (AS only 6, 7 and 8)

Model Size: 1 - 11 (according to list)

Cylinder type:
I = Internal Cylinder
E = External Cylinder

Extra open arm:
N = No extra open arm
U = Extra open arm, upper arm
L = Extra open arm, lower arm
B = Extra open arm, both arms

Lubrication Type:
A = Automatic
M = Manual

Lubricant:
O = Oil
G = Grease

Roller type:
S = Standard
C = Cambered

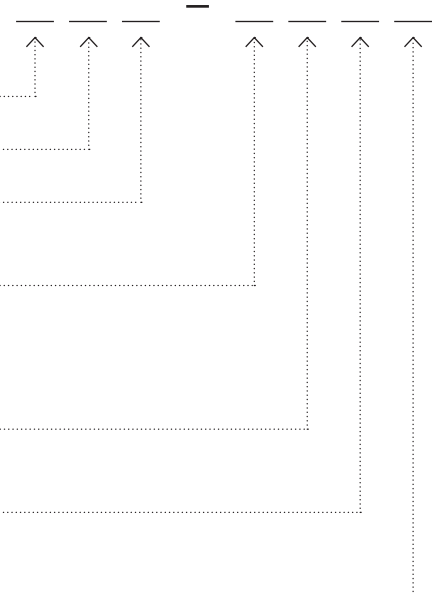

AXI - INTERNAL CYLINDER

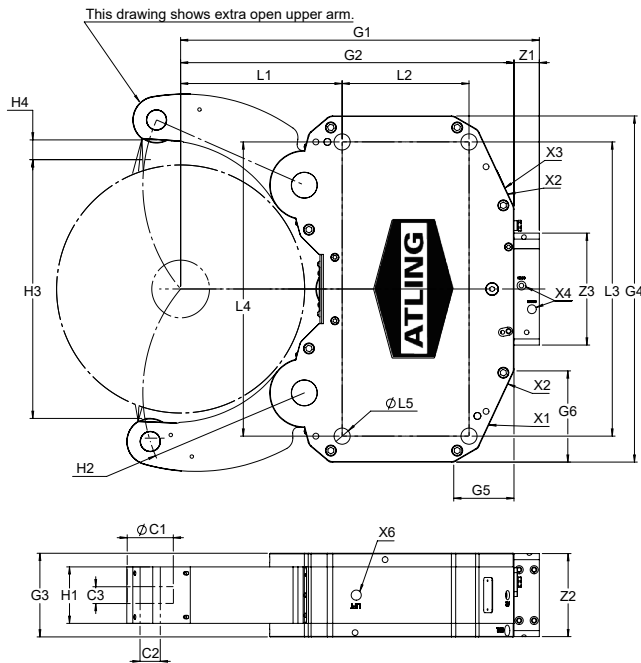

X1 - Central lubrication connection
G1/8"

X2 - Air barrier connection
G1/8"

X3 - Water flush connection
G1/4"

X4 - Hydraulic Open/Close
G3/8" (AX31-G1/8")

Min operating pressure - 20 bar

Model size		AX31	AX41	AX51	AX61	AX71	AX81	AX8.51	AX8.71	AX91	AX9.51	AX9.71	AX101	AX111
Gripping range		12-125	12-160	20-200	30-255	45-320	85-360	100-430	140-470	100-510	340-600	360-620	250-680	450-870
Roller	(mm) C1	Ø35	Ø47	Ø52	Ø52	Ø62	Ø72	Ø80	Ø80	Ø80	Ø80	Ø80	Ø100	Ø160
	(mm) C2	Ø15	Ø20	Ø20	Ø20	Ø30	Ø30	Ø35	Ø35	Ø35	Ø35	Ø35	Ø45	Ø65
	(mm) C3	19	25	25	25	29	29	29	29	29	29	29	32	75
Lever	(mm) H1	37	53	53	53	68	68	98	98	98	98	98	98	118
	(mm) H2	R88	R116	R140	R168	R215	R235	R280	R300	R325	R370	R380	R430	R606
	(mm) H3	128	168	208	267	331	377	448	491	521	611	640	686	930
	(mm) H4	8	10	15	24	27	38	27	33	38	10,5	11	38	33
Housing	(mm) G1	275	334	368	434	509	537	622	647	705	731	744	847	1244
	(mm) G2	231	290	314	380	465	493	578	603	661	687	700	803	1200
	(mm) G3	70	90	90	110	145	145	145	145	145	145	145	165	198
	(mm) G4	270	315	315	438	500	500	600	600	700	670	670	760	1200
	(mm) G5	56	45	38	83	102	97	104	104	156	113	113	108	135
	(mm) G6	68	45	66	133	105	100	158	158	220	177	177	188	254
Hole pattern	(mm) L1	77	115	123	146	178	208,5	280	305,5	292,5	323	336	415	640
	(mm) L2	102	135	135	155	210	210	220	220	260	270	270	312	400
	(mm) L3	220	262	262	365	400	400	510	510	620	500	500	470	670
	(mm) L4	210	262	262	365	400	400	510	510	620	620	620	700	1100
	(mm) L5	Ø14	Ø18	Ø18	Ø23	Ø23	Ø23	Ø28	Ø28	Ø28	Ø28	Ø28	Ø35	Ø35
Cylinder	(mm) Z1	44	44	54	54	44	44	44	44	44	44	44	44	44
	(mm) Z2	70	89	89	109	144	144	144	144	144	145	145	144	197
	(mm) Z3	124	158	158	158	164	164	194	194	194	194	194	194	260
Lifting threads	(mm) X6	-	M16	M16	M16	M16	M20	M20	M20	M20	M20	M20	M24	M30
Max gripping force/roller	(daN)	390	1170	1170	1480	1830	1830	2260	2260	2260	2260	2260	2260	3070
Max roller speed	(m/min)	930	805	890	890	655	765	685	685	685	685	685	685	457
Centering accuracy	(mm)	0,04	0,04	0,06	0,06	0,06	0,06	0,06	0,06	0,10	0,10	0,10	0,10	0,20
Repeatability	(mm)	0,005	0,005	0,005	0,005	0,005	0,005	0,01	0,10	0,02	0,02	0,02	0,02	0,02
Max operating pressure	(bar)	60	70	70	70	70	70	60	60	60	60	60	60	60
Weight	(kg)	21	40	42	78	145	147	220	223	270	270	270	440	1360

AXE - EXTERNAL CYLINDER

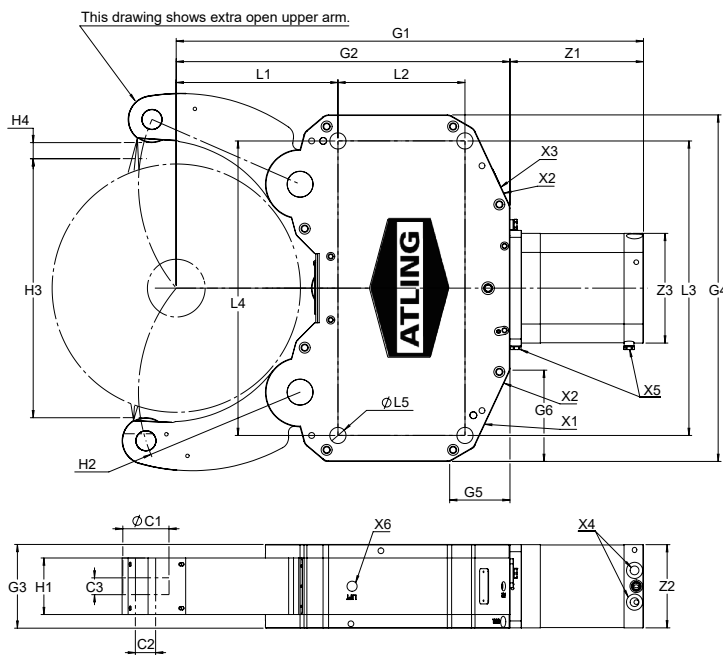

X1 - Central lubrication connection
G1/8"

X2 - Air barrier connection
G1/8"

X3 - Water flush connection
G1/4" (AX1E - G1/8")

X4 - Hydraulic Open/Close
G3/8" (AX1E - G1/4")

X5 - Stroke control thread
M12x1 (AX1E - M8x1)

Min operating pressure - 10 bar

Model size		AX1E	AX2E	AX3E	AX4E	AX5E	AX6E	AX7E	AX8E	AX8.5E	AX8.7E	AX9E	AX10E	AX11E
Gripping range		6-70	8-105	12-125	12-160	20-200	30-255	45-320	85-360	100-430	140-470	100-510	250-680	450-870
Roller	(mm) C1	Ø24	Ø35	Ø35	Ø47	Ø52	Ø52	Ø62	Ø72	Ø80	Ø80	Ø80	Ø100	Ø160
	(mm) C2	Ø8	Ø15	Ø15	Ø20	Ø20	Ø20	Ø30	Ø30	Ø35	Ø35	Ø35	Ø45	Ø65
	(mm) C3	15	19	19	25	25	25	29	29	29	29	29	32	75
Lever	(mm) H1	30	37	37	53	53	53	68	68	98	98	98	98	118
	(mm) H2	R55	R75	R88	R116	R140	R168	R215	R235	R280	R300	R325	R430	R606
	(mm) H3	75	110	128	168	208	267	331	377	448	491	521	686	930
	(mm) H4	5	2	8	10	15	24	27	38	27	33	38	38	33
Housing	(mm) G1	220	301	344	428	465	563	669	697	809	840	938	1103	1578
	(mm) G2	137	200	231	290	314	380	465	493	578	603	661	803	1200
	(mm) G3	60	70	70	90	90	110	145	145	145	145	145	165	198
	(mm) G4	163	215	270	315	315	438	500	500	600	600	700	760	1200
	(mm) G5	17	43	56	45	38	83	102	97	104	104	156	108	135
	(mm) G6	27	37	68	45	66	133	105	100	158	158	220	188	254
Hole pattern	(mm) L1	51	70	77	115	123	146	178	208,5	280	305,5	292,5	415	640
	(mm) L2	64	85	102	135	135	155	210	210	220	220	260	312	400
	(mm) L3	118	170	220	262	262	365	400	400	510	510	620	470	670
	(mm) L4	118	170	210	262	262	365	400	400	510	510	620	700	1100
	(mm) L5	Ø11	Ø14	Ø14	Ø18	Ø18	Ø23	Ø23	Ø23	Ø28	Ø28	Ø28	Ø35	Ø35
Cylinder	(mm) Z1	83	101	113	138	151	183	204	204	231	237	277	300	378
	(mm) Z2	60	70	70	89	89	109	144	144	144	144	144	144	197
	(mm) Z3	86	106	106	128	128	140	155	155	190	190	190	190	250
Lifting threads	(mm) X6	-	-	-	M16	M16	M16	M16	M20	M20	M20	M20	M24	M30
Max gripping force/roller	(daN)	100	390	390	1170	1170	1480	1830	1830	2260	2260	2260	2260	3070
Max roller speed	(m/min)	730	930	930	805	890	890	655	765	685	685	685	685	457
Centering accuracy	(mm)	0,02	0,02	0,04	0,04	0,06	0,06	0,06	0,06	0,06	0,06	0,10	0,10	0,20
Repeatability	(mm)	0,005	0,005	0,005	0,005	0,005	0,005	0,005	0,005	0,01	0,01	0,02	0,02	0,02
Max operating pressure	(bar)	25	60	60	70	70	70	70	70	60	60	60	60	60
Weight	(kg)	8	17	23	45	48	83	158	156	234	237	280	450	1415

ASI - INTERNAL CYLINDER

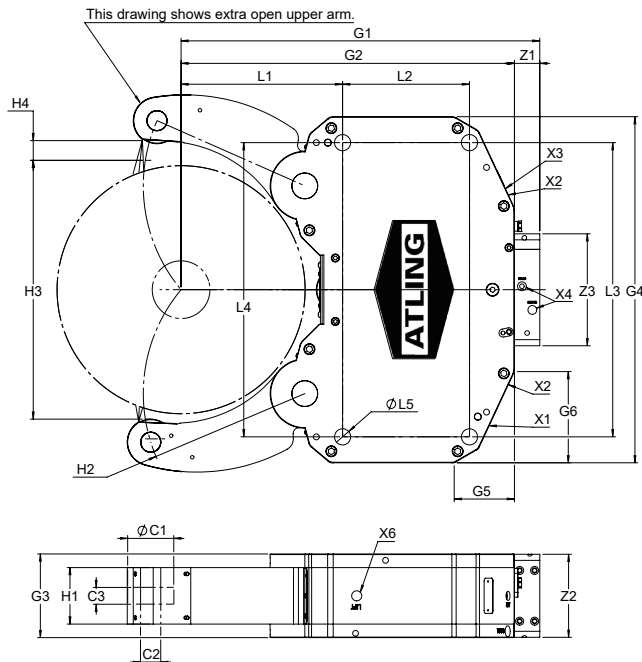

X1 - Central lubrication connection
G1/8"

X2 - Air barrier connection
G1/8"

X3 - Water flush connection
G1/4"

X4 - Hydraulic Open/Close
G3/8"

Min operating pressure - 20 bar

Model size		AS6I	AS7I	AS8I
Gripping range		30-255	45-320	85-360
Roller	(mm) C1	Ø52	Ø62	Ø72
	(mm) C2	Ø20	Ø30	Ø30
	(mm) C3	25	29	29
Lever	(mm) H1	53	68	68
	(mm) H2	R168	R215	R235
	(mm) H3	267	331	377
	(mm) H4	24	27	38
Housing	(mm) G1	434	509	537
	(mm) G2	403	465	493
	(mm) G3	110	145	145
	(mm) G4	438	500	500
	(mm) G5	113	105	100
	(mm) G6	20	38	42
Hole pattern	(mm) L1	146	178	198
	(mm) L2	240	270	270
	(mm) L3	365	400	400
	(mm) L4	365	400	400
	(mm) L5	Ø23	Ø23	Ø23
Cylinder	(mm) Z1	54	44	44
	(mm) Z2	109	144	144
	(mm) Z3	158	164	164
Lifting threads	(mm) X6	M16	M16	M20
Max gripping force/roller	(daN)	1480	1830	1830
Max roller speed	(m/min)	890	655	765
Centering accuracy	(mm)	0,06	0,06	0,06
Repeatability	(mm)	0,005	0,005	0,005
Max operating pressure	(bar)	70	70	70
Weight	(kg)	84	155	153

ASE - EXTERNAL CYLINDER

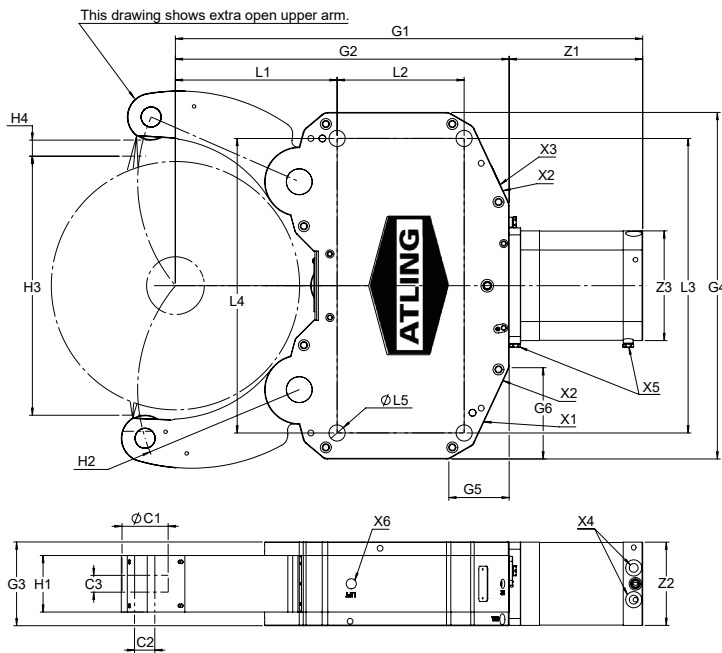

X1 - Central lubrication connection
G1/8"

X2 - Air barrier connection
G1/8"

X3 - Water flush connection
G1/4"

X4 - Hydraulic Open/Close
G3/8"

X5 - Stroke control thread
M12x1

Min operating pressure - 10 bar

Model size		AS6E	AS7E	AS8E
Gripping range		30-255	45-320	85-360
Roller	(mm) C1	Ø52	Ø62	Ø72
	(mm) C2	Ø20	Ø30	Ø30
	(mm) C3	25	29	29
Lever	(mm) H1	53	68	68
	(mm) H2	R168	R215	R235
	(mm) H3	267	331	377
	(mm) H4	24	27	38
Housing	(mm) G1	563	669	697
	(mm) G2	403	465	493
	(mm) G3	110	145	145
	(mm) G4	438	500	500
	(mm) G5	113	105	100
	(mm) G6	20	38	42
Hole pattern	(mm) L1	146	178	198
	(mm) L2	240	270	270
	(mm) L3	365	400	400
	(mm) L4	365	400	400
	(mm) L5	Ø23	Ø23	Ø23
Cylinder	(mm) Z1	182	204	204
	(mm) Z2	109	144	144
	(mm) Z3	140	155	155
Lifting threads	(mm) X6	M16	M16	M20
Max gripping force/roller	(daN)	1480	1830	1830
Max roller speed	(m/min)	890	655	765
Centering accuracy	(mm)	0,06	0,06	0,06
Repeatability	(mm)	0,005	0,005	0,005
Max operating pressure	(bar)	70	70	70
Weight	(kg)	92	167	165

ANE - NARROW ARMS

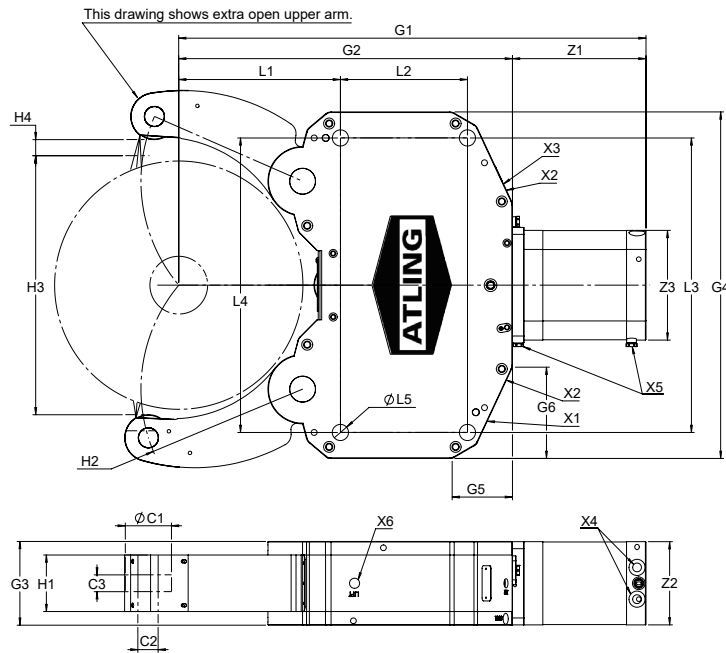

X1 - Central lubrication connection
G1/8"

X2 - Air barrier connection
G1/8"

X3 - Water flush connection
G1/4" (AN1E - G1/8")

X4 - Hydraulic Open/Close
G3/8" (AN1E - G1/4")

X5 - Stroke control thread
M12x1 (AN1E - M8x1)

Min operating pressure - 10 bar

Model size		AN1E	AN2E	AN3E	AN4E
Gripping range		6-70	8-105	12-125	12-160
Roller	(mm) C1	Ø24	Ø35	Ø35	Ø47
	(mm) C2	Ø8	Ø15	Ø15	Ø20
	(mm) C3	10	10	10	10
Lever	(mm) H1	19	19	19	19
	(mm) H2	R55	R75	R88	R116
	(mm) H3	75	110	128	168
	(mm) H4	5	2	8	10
Housing	(mm) G1	220	301	344	428
	(mm) G2	137	200	231	290
	(mm) G3	60	70	70	90
	(mm) G4	163	215	270	315
	(mm) G5	17	43	56	45
	(mm) G6	27	37	68	45
Hole pattern	(mm) L1	51	70	77	115
	(mm) L2	64	85	102	135
	(mm) L3	118	170	220	262
	(mm) L4	118	170	210	262
	(mm) L5	Ø11	Ø14	Ø14	Ø18
Cylinder	(mm) Z1	83	101	113	138
	(mm) Z2	60	70	70	89
	(mm) Z3	86	106	106	128
Lifting threads	(mm) X6	-	-	-	M16
Max gripping force/roller	(daN)	60	190	190	500
Max roller speed	(m/min)	730	930	930	805
Centering accuracy	(mm)	0,02	0,02	0,04	0,04
Repeatability	(mm)	0,005	0,005	0,005	0,005
Max operating pressure	(bar)	15	30	30	30
Weight	(kg)	8	17	23	45

SHAFT KIT

One shaft for middle piece and two shafts for arms.

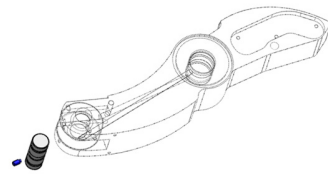
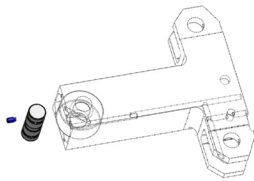

Model	1	2	3	4	5	6	7	8	8.5	8.7	9	9.5	9.7	10	11
AX/AS	A5550105	A5550205	A5550305	A5550405	A5550505	A5550605	A5550705	A5550805	A5550905	A5550905	A5550905	A5550905	A5550905	A5551005	A5551105

WIPER KIT

One wiper for middle piece and two wipers for arms.

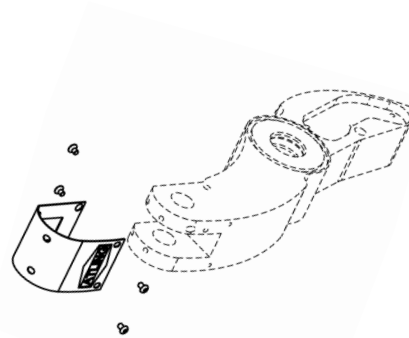
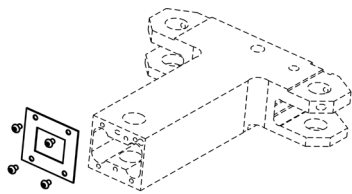

Model	1	2	3	4	5	6	7	8	8.5	8.7	9	9.5	9.7	10	11
AX/AS	A5550103	A5550203	A5550303	A5550403	A5550503	A5550603	A5550703	A5550803	A5550903	A5550903	A5550903	A5550903	A5550903	A5551003	A5551103

ROLLER BEARINGS

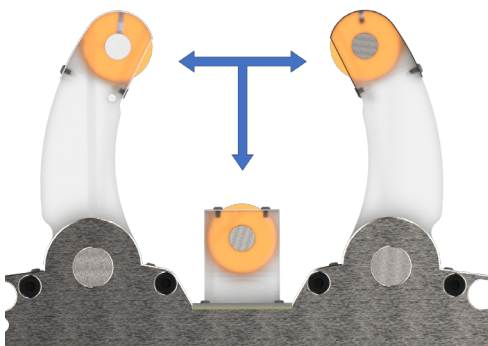

» Cylindrical Roller



Standard roller

» Cambered Roller

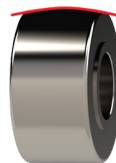

Used when the steady rest travels along the work piece.

Model	1	2	3	4	5	6	7	8	8.5	8.7	9	9.5	9.7	10	11
Cylindrical	A5055044	A5055040	A5055040	A5055014	A5055026	A5055026	A5055005	A5055008	A5055017	A5055017	A5055017	A5055017	A5055017	A5551310	A5551311
Cambered	A5055050	A5551203	A5551203	A5551204	A5551205	A5551205	A5551207	A5551208	A5551209	A5551209	A5551209	A5551209	A5551209	A5551210	A5551211

WORKPIECE WIPER

» Manual workpiece wiper.



The manual workpiece wiper is used to remove dirt and chips from the workpiece. It's manually adjusted and can be assembled in existing holes on standard arms. It has to be manually adjusted when the working diameters are changed.

» Resilient workpiece wiper.

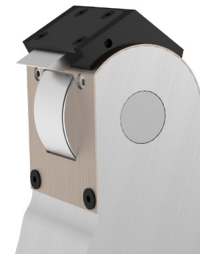

The resilient workpiece wiper is used to remove dirt and chips from the workpiece. Its spring function makes it automatically adjusted to the workpiece surface. It is assembled in existing holes on standard arms.

Model	AX1	AX2	AX3	AX4	AX5	AX6	AX7	AX8	AX8.5	AX8.7	AX9	AX9.5	AX9.7	AX10	AX11
Standard	A51001	A51002	A51002	A51004	A51005	A51005	A51007	A51008	A51009	A51009	A51009	A51009	A51009	A51010	A51011
Resilient		A50002	A50002	A50004	A50005	A50005	A50007	A50008	A50009	A50009	A50009	A50009	A50009	A50010	A50011

ECCENTRIC FINE ADJUSTMENT KIT

Eccentric roller pins on the arms provides a quick fine adjustment of the center line.



Model	AX1	AX2	AX3	AX4	AX5	AX6	AX7	AX8	AX8.5	AX8.7	AX9	AX9.5	AX9.7	AX10	AX11
				A60040	A60040	A60040	A43361	A43361	A43237	A43237	A43237	A43237	A43237	A60100	

EXAMPLES OF CUSTOM-MADE STEADYRESTS

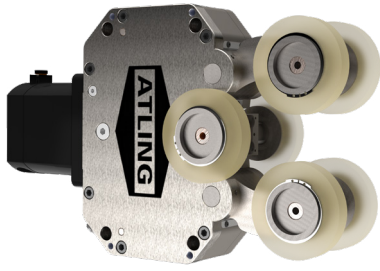

» Rubber Rollers

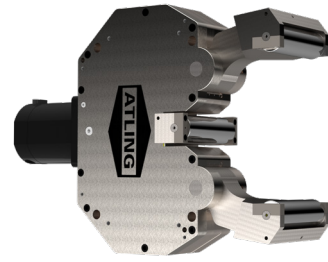

» Wide Rollers

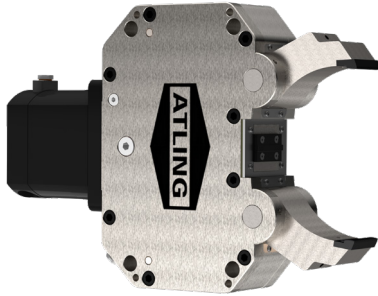

» Diamond Pads



» Pneumatic driven
» Coolant driven

ZERO POINT CLAMPING BRACKET



» Zero Point Clamping

The ZPC-Bracket provides fast mounting/dismounting of steady rests, with repeatability of 2.5μ and can be customized for any turning machine.

The steady rest is placed in the same position, every time it's clamped and doesn't have to be re-adjusted.

BRACKETS & ADAPTER PLATES

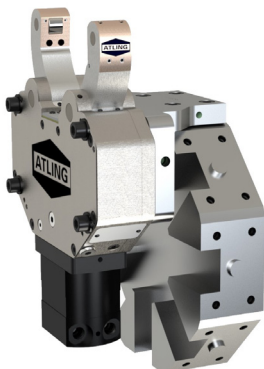

» Turret Bracket

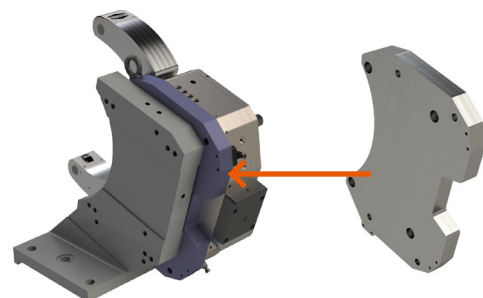

» Adapter Plates



Atlings Maskinfabrik AB
P.O. Box 21
SE 816 25 Ockelbo, Sweden
+46 297 557 00
steadyrest@atling.se
www.atling.com